

Calder

- | | | |
|---|---|--|
| D Montageanleitung
Bett Calder | GB Assembly instructions
Bed Calder | FR Notice de montage
Lit Calder |
| NL Montage-instructies
Bed Calder | PL Instrukcje montazu
Łózko Calder | SK Návod na montáž
Postel Calder |
| TR Montaj talimatları
Yatak Calder | RU Инструкция по монтажу
Bed Calder | HU Szerelési útmutató
Agy Calder |
| IT Istruzioni di montaggio
Letto Calder | CZ Montážní návod
Postel Calder | RO Instrucțiuni de montaj
Pat Calder |

**Service • Assistenza • Dienstverlening • Servis
Servis • Szerviz • Сервисная служба**

Name • Nom • Nome • Naam • Nazwa • Jméno • Názov • Név • Denumire • sim •	Calder
Nr. • No. • N° • • • Sz	
Typ • Type • Tip • Típus • Tipo •	

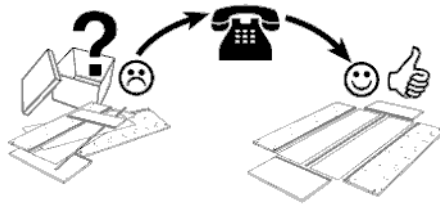
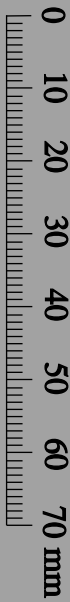
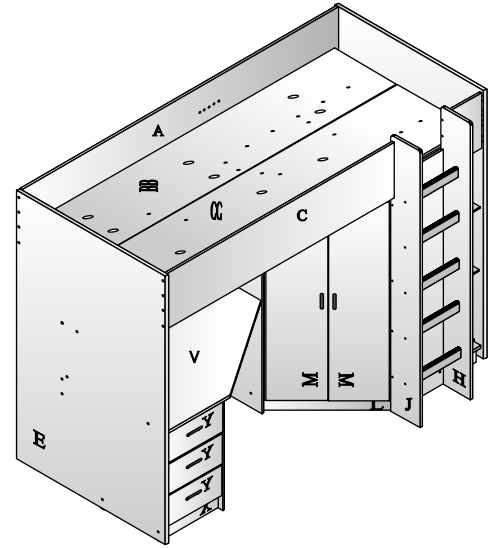

A - 1	D - 2	G - 1	K - 1		R - 1	V - 1	Y - 3	BB - 1	1 - 130 x 40cm x 3mm
B - 1	E - 1	H - 1	L - 1	P - 1	S - 1	W - 1	Z - 1	CC - 1	1 - 131 x 98cm x 3mm
C - 1	F - 1	J - 1	M - 2	Q - 1	T - 1	X - 2	AA - 1		1 - 102 x 37cm x 3mm
									1 - 102 x 33cm x 3mm
									3 - 35 x 34cm x 3mm

10 x "23"	2 x "118"	34 x "44"	1 x "25"	60 x "28"	54 x "13"	62 x "43"	1 "124" 96cm
4 x "214"	4 x "216"	10 x "18"	5 x "131"	5 "569"	1 x "151"	28 x "155"	
4 x "14"	25 x "30"	10 x "238"	19 x "106"	60 x "104"	11 x "156"	11 x "38"	2 x "165"
6 x "74"	10 x "19"	77 x "220"	17	2 x "219"	4 x "54"	6 x "47"	3 x "222"
2 x "92"	2 x "181"	2 x "182"			3 x "63"		

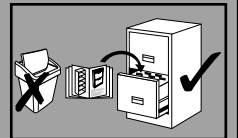
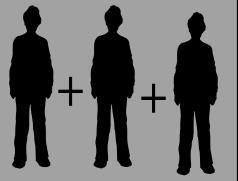

EN 747-1:2012+A1:2015

IMPORTANT - À LIRE ATTENTIVEMENT - CONSERVER POUR RÉFÉRENCE
ULTÉRIEURE

WICHTIG - BITTE SORGFÄLTIG LESEN - BEHALTEN FÜR ZUKÜNFTIGE
VERWEIS

BELANGRIJK - LEES ZORGVULDIG - BEHOUDEN VOOR TOEKOMSTIGE
REFERENTIE

IMPORTANT - READ CAREFULLY - RETAIN FOR FUTURE REFERENCE

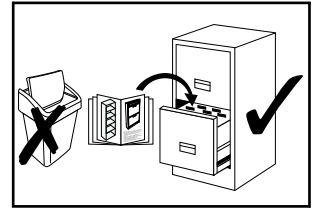

- 1. WARNING;** High Beds and the upper beds of bunk beds are not suitable for children under six years of age due to the risk of injury from falls.
- 2. WARNING;** Bunk beds and High beds can present a serious risk of injury from strangulation if not used correctly. Never attach or hang items to any part of the bunk bed or high bed that are not designed to be used with the bed, for example, but not limited to ropes, strings, cords, hooks, belts and bags.
- 3. WARNING;** Children can become trapped between the bed and the wall, a roof pitch, the ceiling, adjoining pieces of furniture (e.g. Cupboards) and the like. To avoid risk of serious injury the distance between the top safety barrier and the adjoining structure shall not exceed 75 mm or shall be more than 230 mm.
- 4. WARNING;** Do not use the bunk bed or high bed if any structural part is broken or missing.
5. Always follow the manufacturers instructions to assemble the bed.
6. The recommended size of mattress for this bed is 200 x 90 x 15cm.
7. The maximum mattress thickness is 15cm. The maximum height is marked on the back panel of the bed.
8. Ventilation of the room is necessary in order to keep the humidity low and to prevent mould in and around the bed.
9. All assembly fastenings, including screws, should be regularly checked to ensure they are properly tightened.
10. The bed is made to EN 747-1:2012+A1:2015 (E).

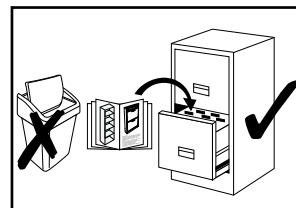

NL

1. **Waarschuwing: Hoogslapers en stapelbedden zijn niet geschikt voor kinderen jonger dan 6 jaar i.v.m. het risico van vallen.**
2. **Waarschuwing: Als het bed niet correct gebruikt wordt is er een verhoogd risico van letsel door verklemming of wurging. Verbind er daarom geen artikelen die geen deel uit maken van het bed zoals ondermeer ; touwen, riemen, koorden, haken en zakken aan .**
3. **Waarschuwing; Om te voorkomen dat kinderen tussen het bed en andere meubels of plafond of muur klem komen te zitten moeten de volgende afstanden tussen de veiligheidsbarriere en de aangrenzende structuur aangehouden worden. De afstand mag niet meer dan 75 mm maar moet meer dan 230mm zijn.**
4. **Waarschuwing; Gebruik het stapelbed of de hoogslaper niet als een structureel onderdeel ontbreekt of gebroken is.**
5. **Bouw het meubel volgens de instructies van de fabricant.**
6. **Aanbevolen matrasmaat 200x90x15cm .**
7. **Maximum matras dikte 15cm. De maximale hoogte is duidelijk op de rug paneel van het bed.**
8. **Ventileer de kamer om schimmel en vocht vorming te voorkomen .**
9. **Alle montage bevestigingen zoals schroeven moeten regelmatig worden gecontroleerd om ervoor te zorgen dat ze goed zijn vastgedraaid.**
10. **Het bed voldoet aan EN 747-1:2012+A1:2015**

F

1. **MISE EN GARDE; Les lits mezzanine et les lits du haut dans les lits superposés ne conviennent pas à des enfants de moins de 6 ans en raison des risques du chute.**
2. **MISE EN GARDE; Si on ne respecte pas les consignes d'utilisation, on peut s'exposer à un sérieux risque de strangulation.**
Il ne faut jamais attacher ou pendre à aucune partie du lit superposé ou du lit mezzanine un élément qui ne soit pas conçu pour être utilisé avec lit, comme, par exemple, des cordes, des ficelles, des cordons, des crochets, des ceintures et des sacs, la liste n'étant pas exhaustive.
3. **MISE EN GARDE; Les enfants peuvent se retrouver coincés entre le lit d'une part et d'autre part le mur, la pente du toit, le plafond, les meubles attenants et autre elements semblables. Pour éviter tout risque de blessure grave, la distance entre la barrière de sécurité du haut et la structure attenante devra faire moins de 75mm ou plus de 230mm.**
4. **MISE EN GARDE; Ne pas utiliser le lit superposé ou le lit mezzanine si un élément de la structure est cassé ou manquant.**
5. **Toujours suivre les instructions du fabricant pour assembler le lit.**
6. **Pour ce lit il est recommandé d'utiliser un matelas 1 personne (200 x 90 x 15cm).**
7. **L'épaisseur du matelas ne doit pas dépasser 15cm. La hauteur maximale est marqué sur le dos panneau du lit**
8. **Il est nécessaire de bien ventiler la chambre pour réduire au maximum le taux d'humidité et empêcher tout risque de moisissure a l'intérieur et autour du lit.**
9. **Tous les éléments permettant la bonne tenue de l'assemblage, y compris les vis, doivent être régulièrement inspectés pour s'assurer qu'ils sont correctement vissés.**
10. **Le lit respecte les normes Europeennes EN 747-1:2012+A1:2015**

Calder High Bed

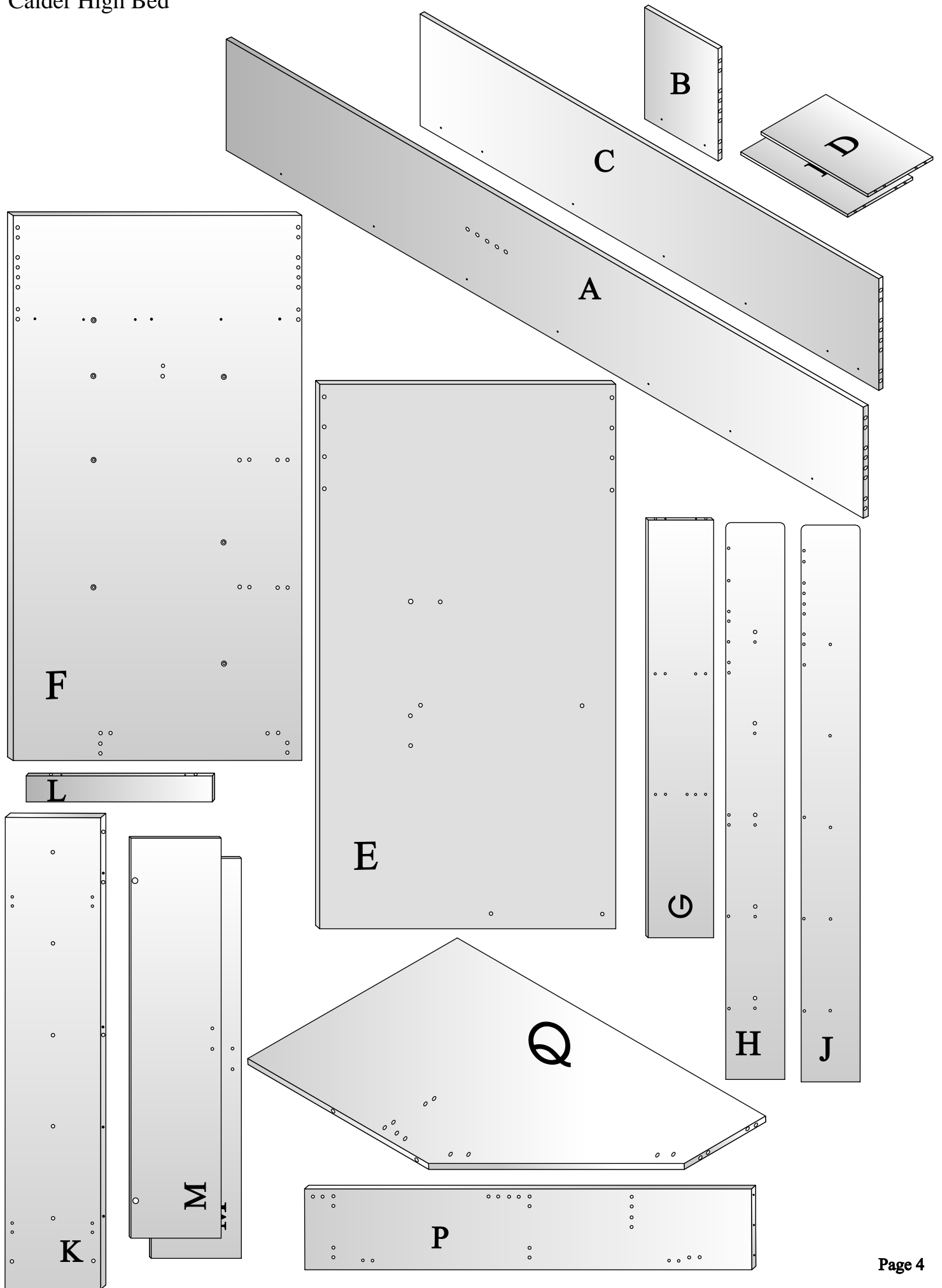

Calder High Bed

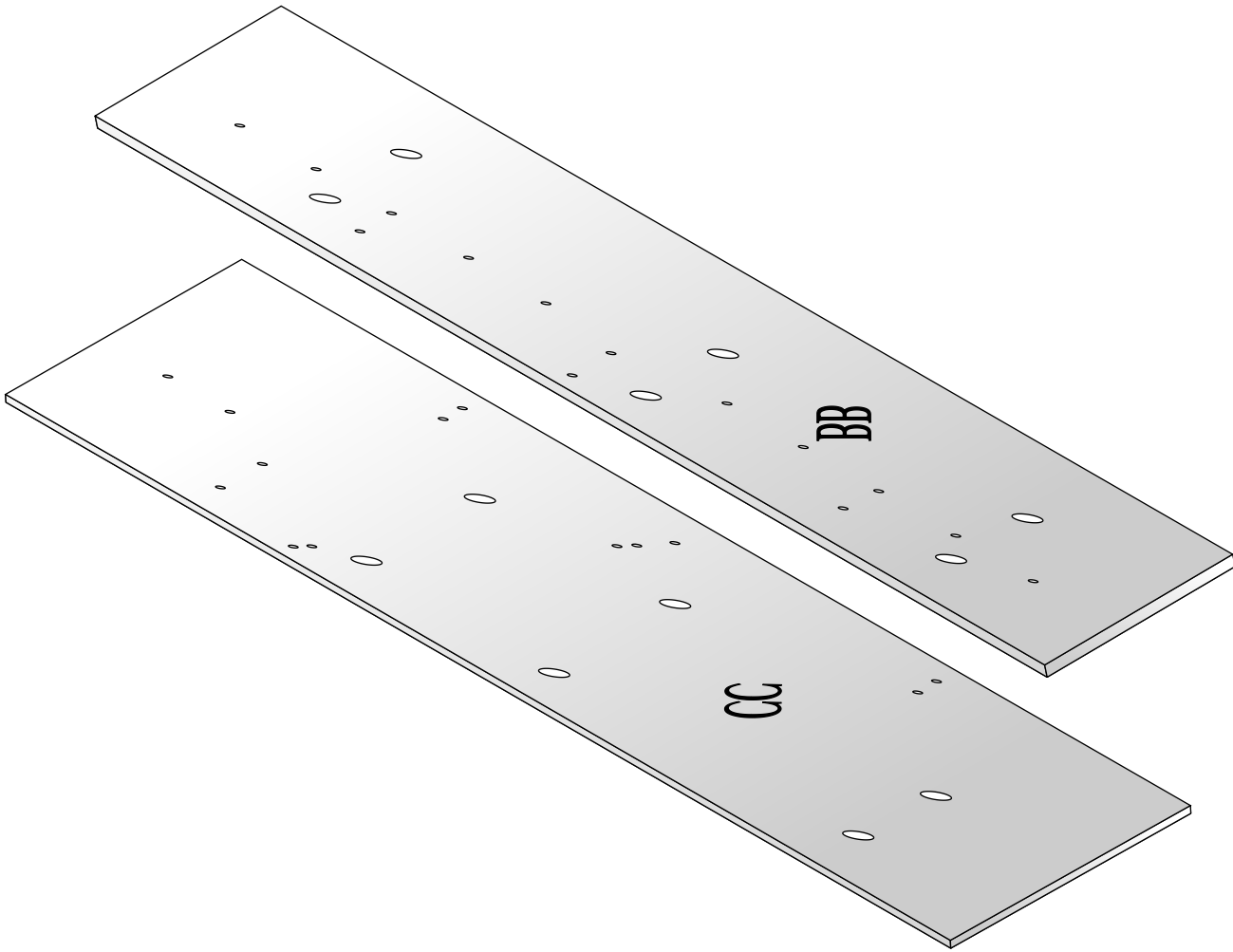
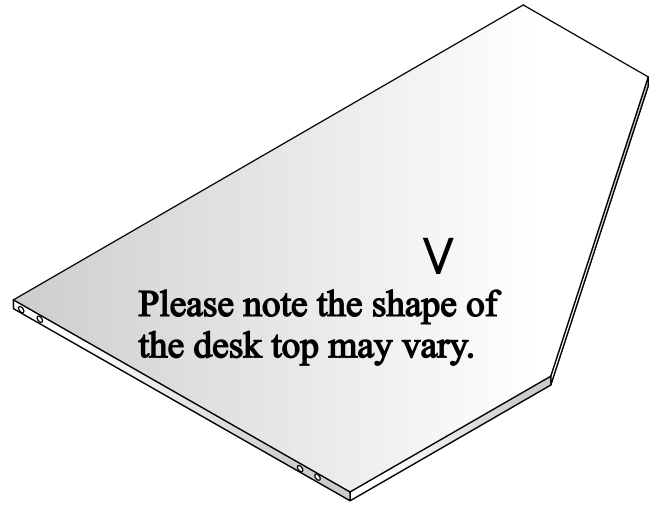
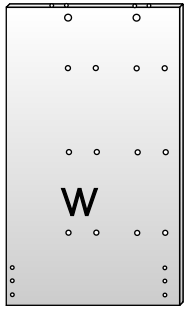
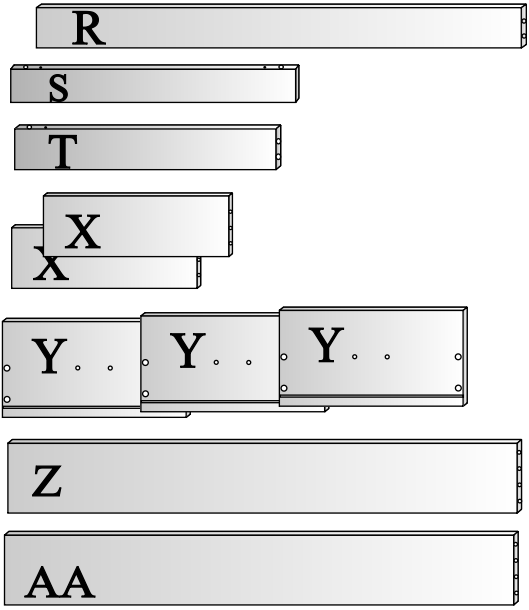



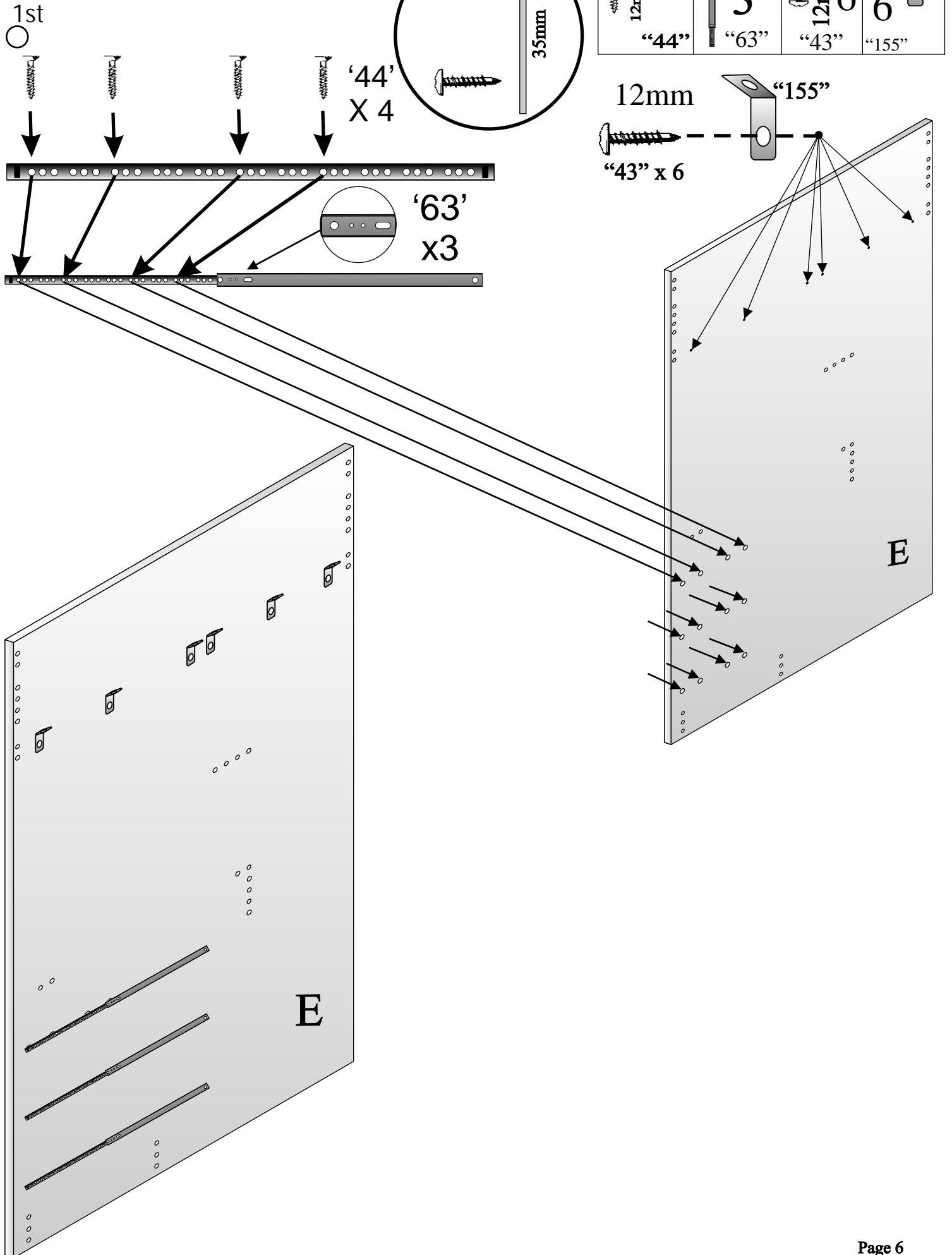

Calder High Bed

Step 1



Calder High Bed
Step 2

 12mm 6 x "43"	 "155" 6 x "155"	 12mm 1 x "44"	 "118" 1 x "118"
---	--	--	--

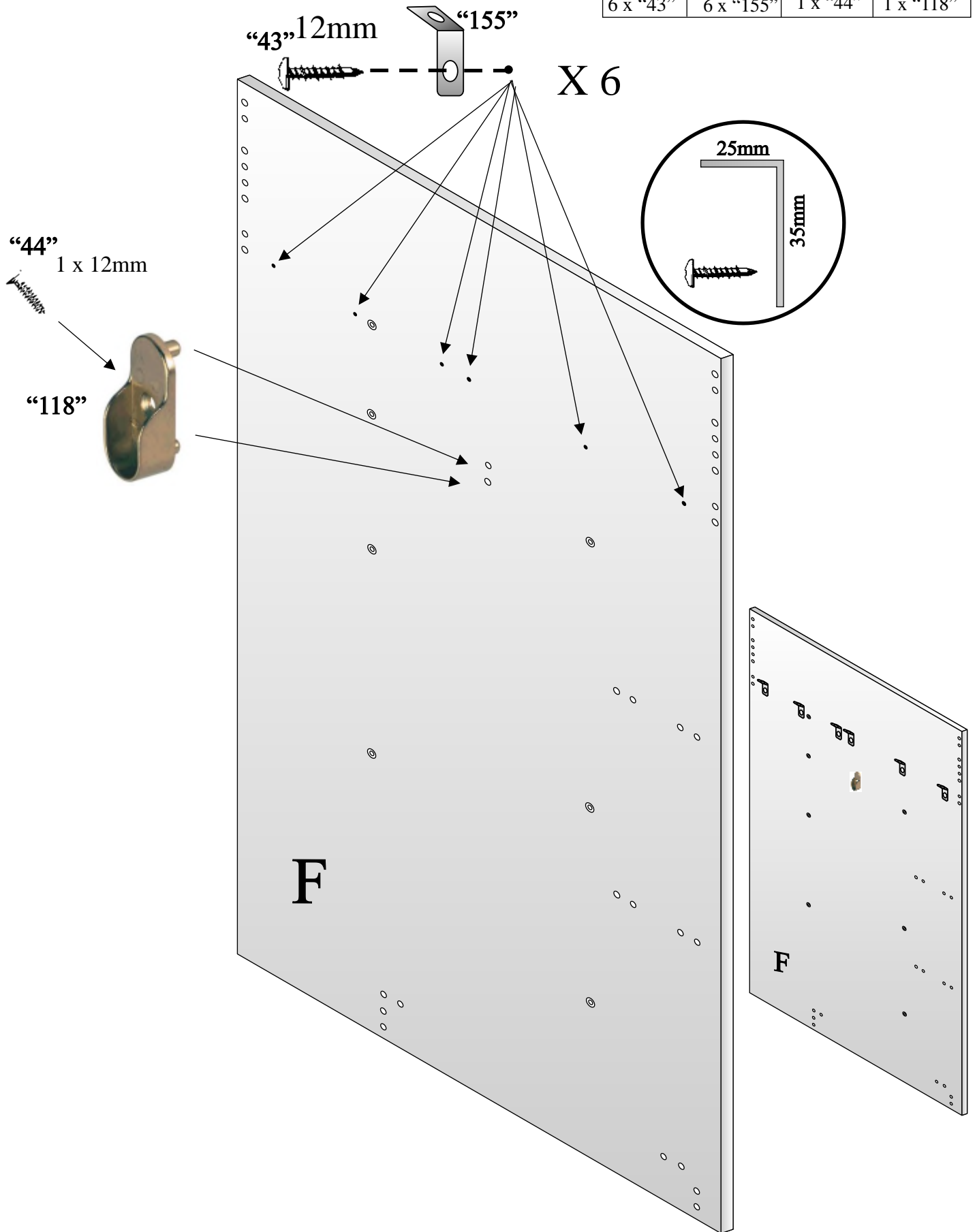

Calder High Bed

Step 3

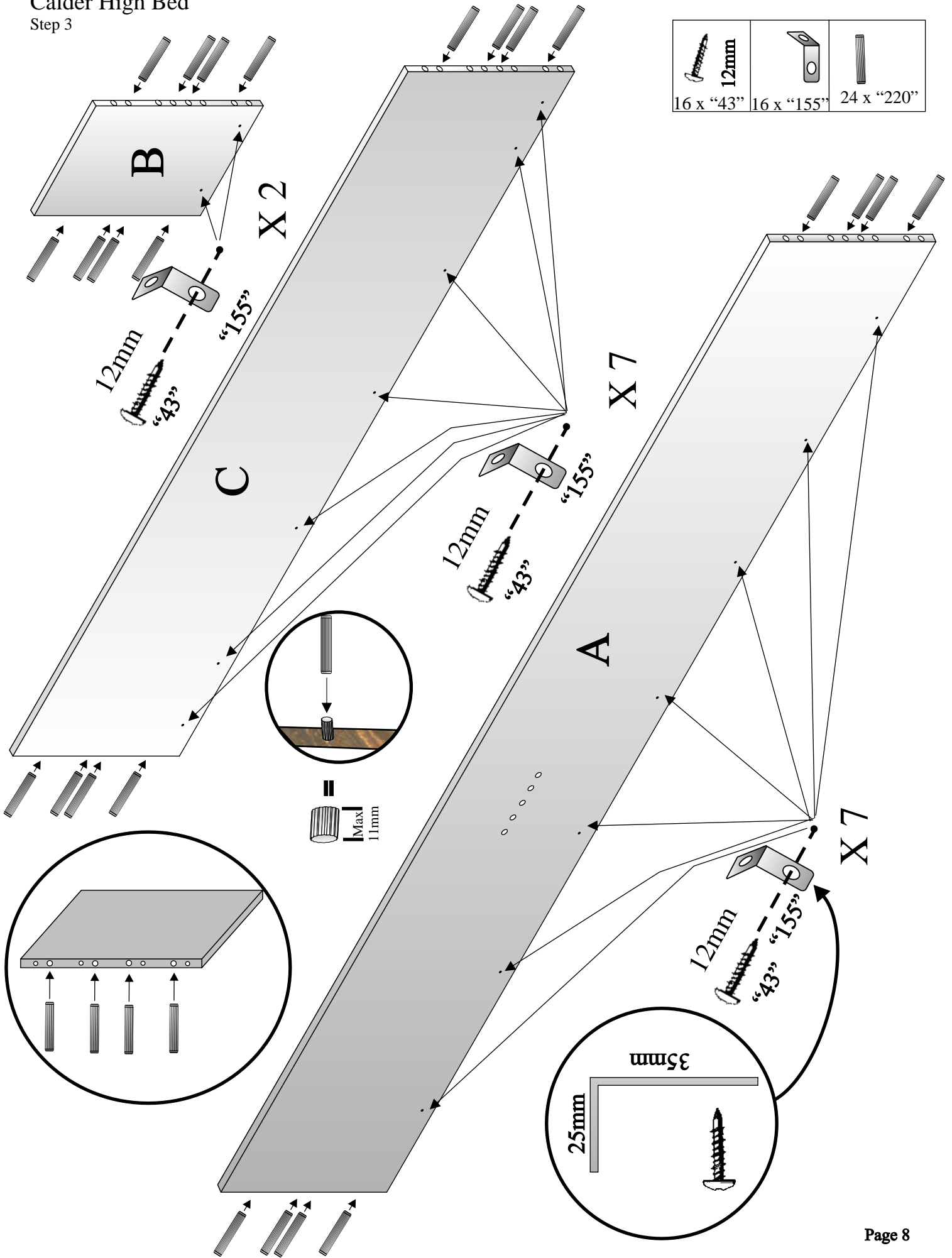

Calder High Bed



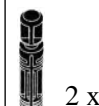
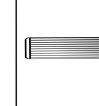
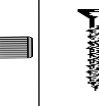
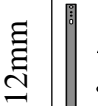

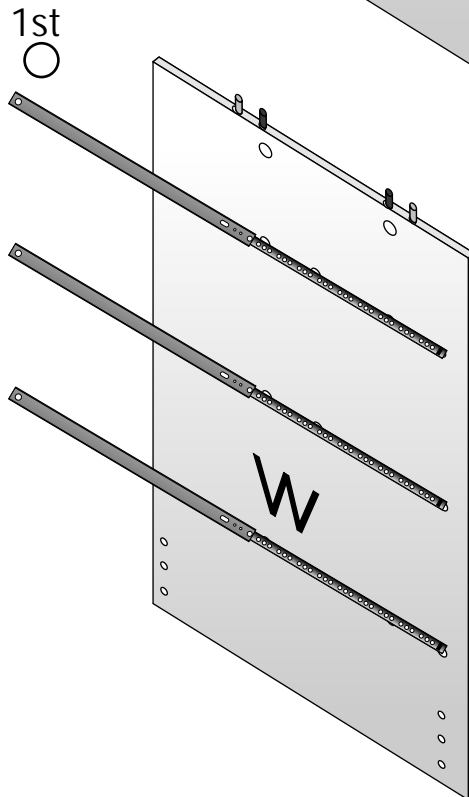
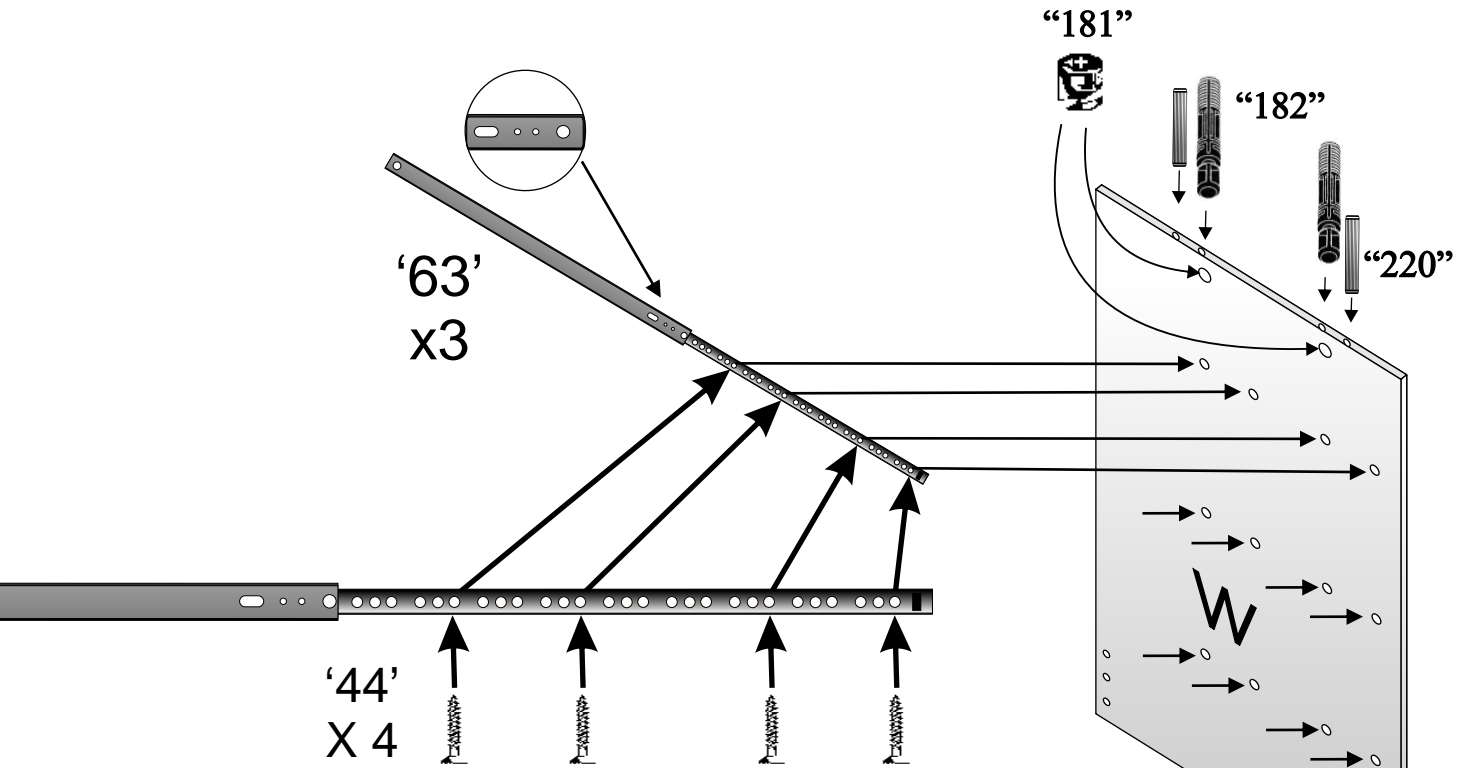
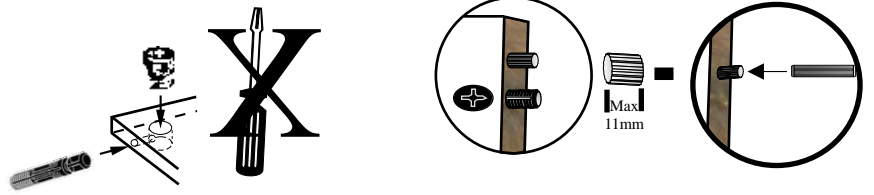
Step 4

 2 x "181"	 2 x "182"	 2 x "220"	 12 x "44"	 3 "63"
---	---	---	---	--





Calder High Bed

Step 5

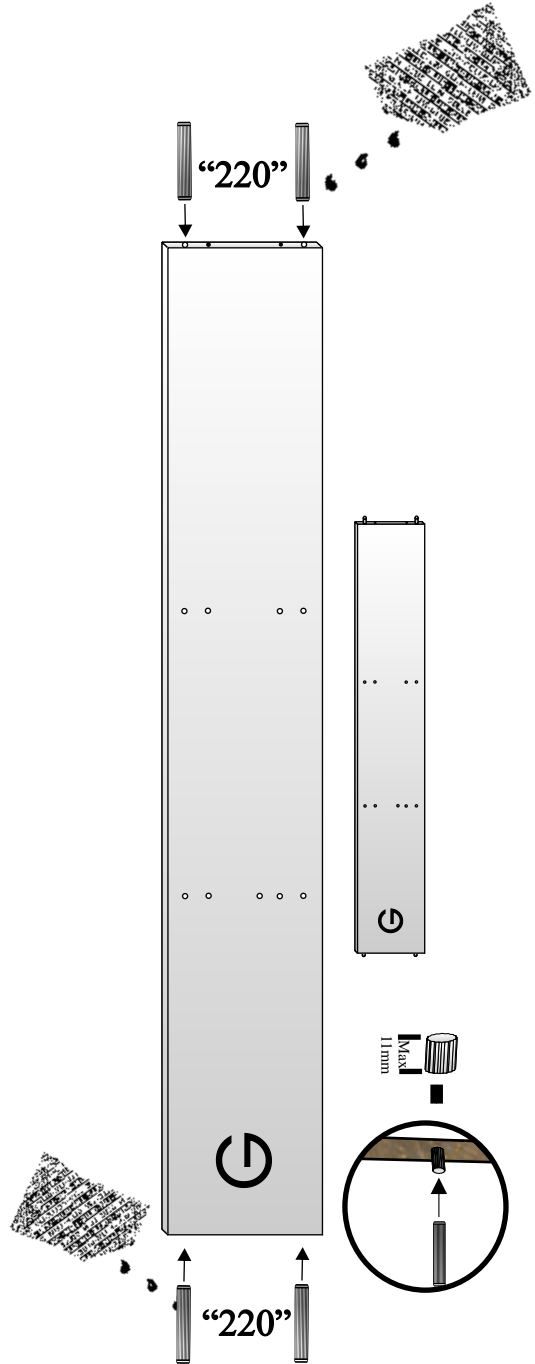
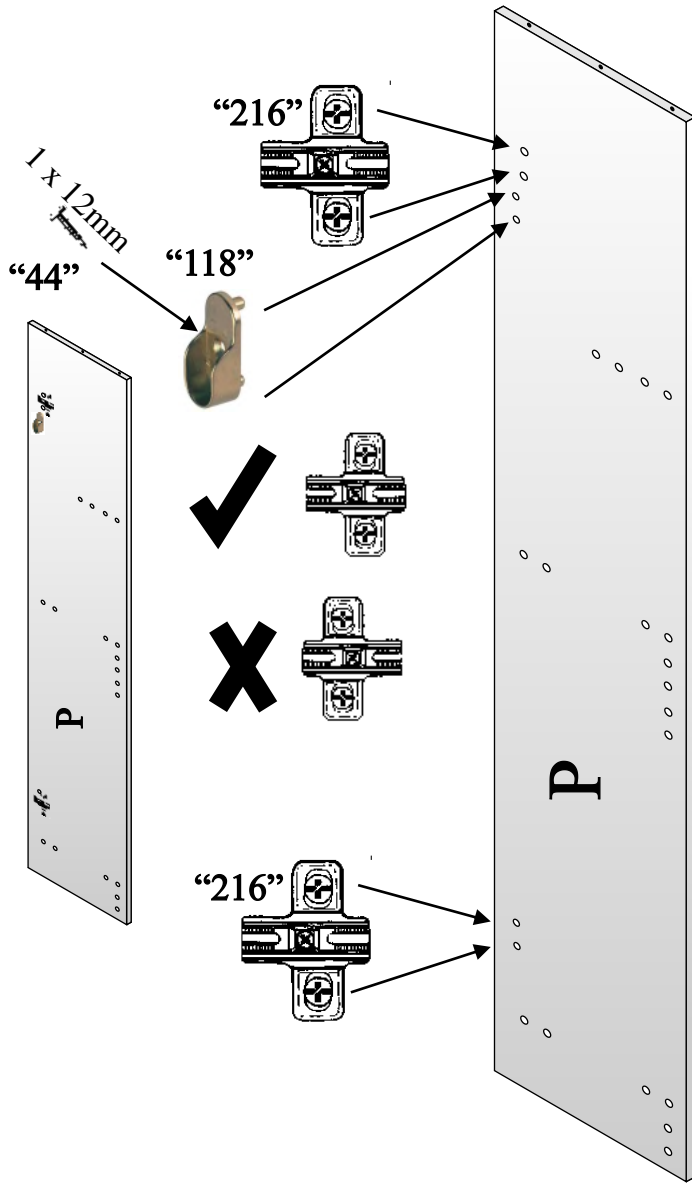
 4 x "220"	 12mm 1 x "44"	 1 x "118"
 2 x "216"		 "219"



Calder High Bed
Step 6

 "219"	 13 x "220"
---	---

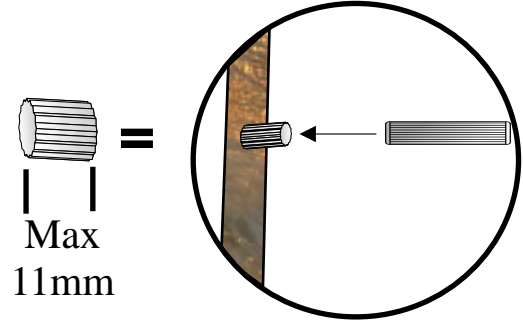

X

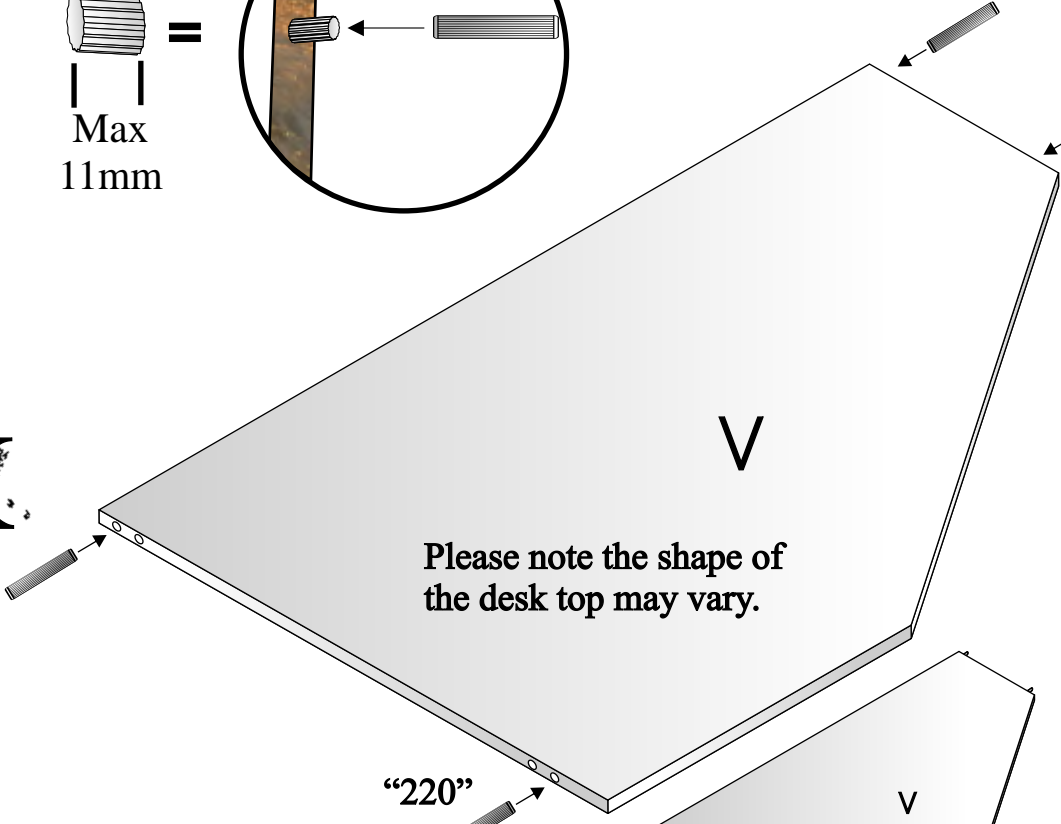

"220"

"220"

X

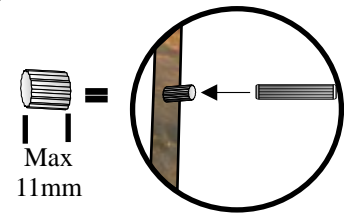

Q

X

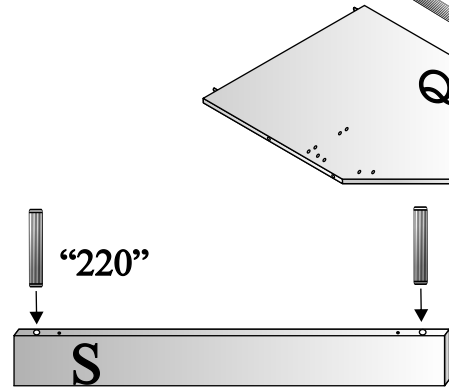
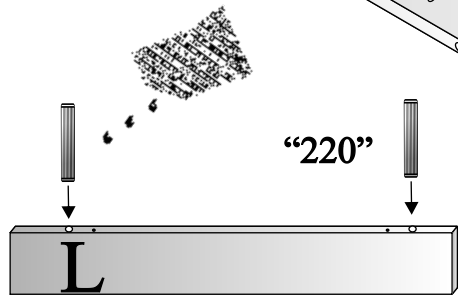

Calder High Bed
Step 7

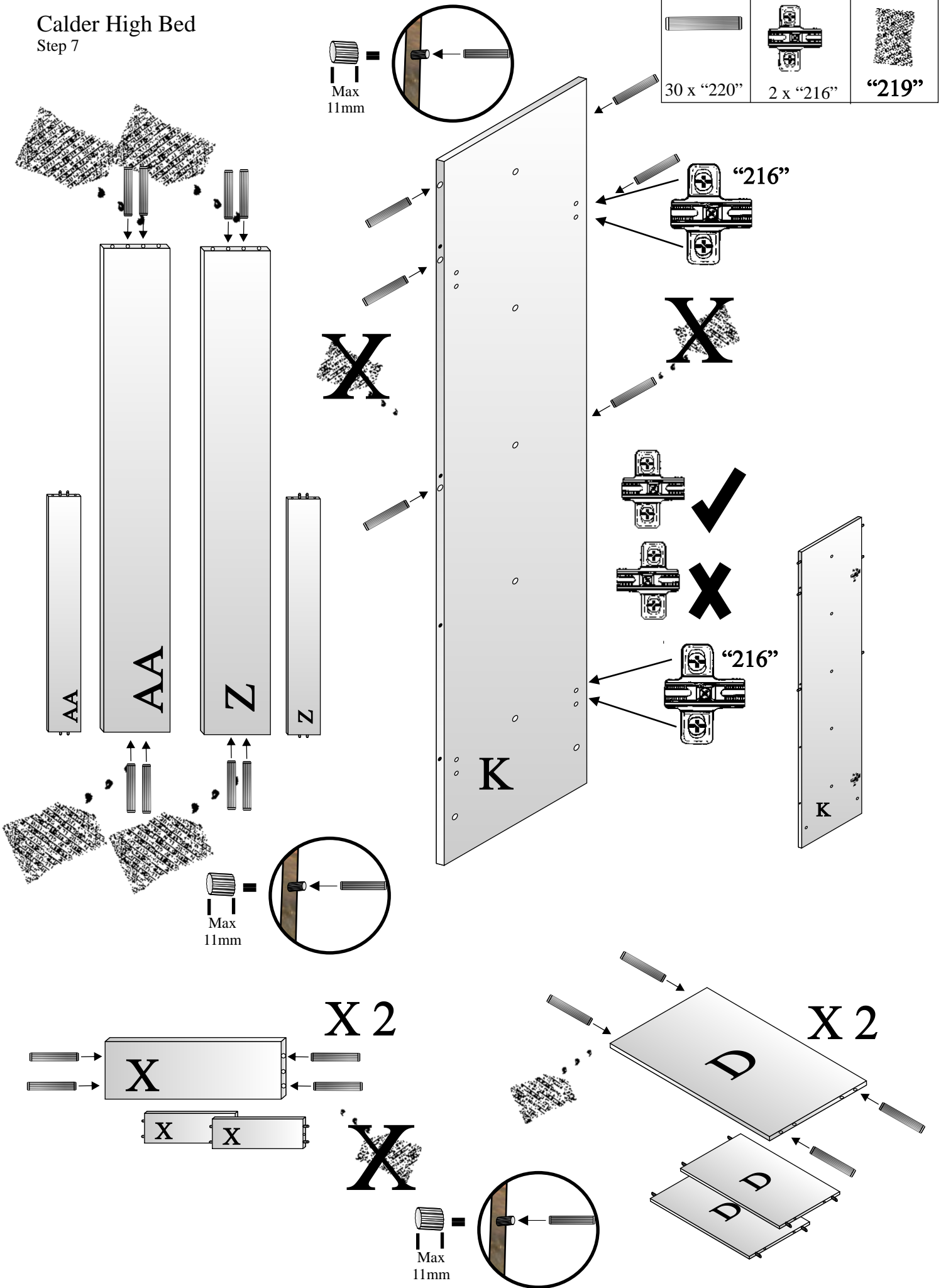

45mm

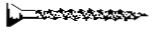

5 x "30"

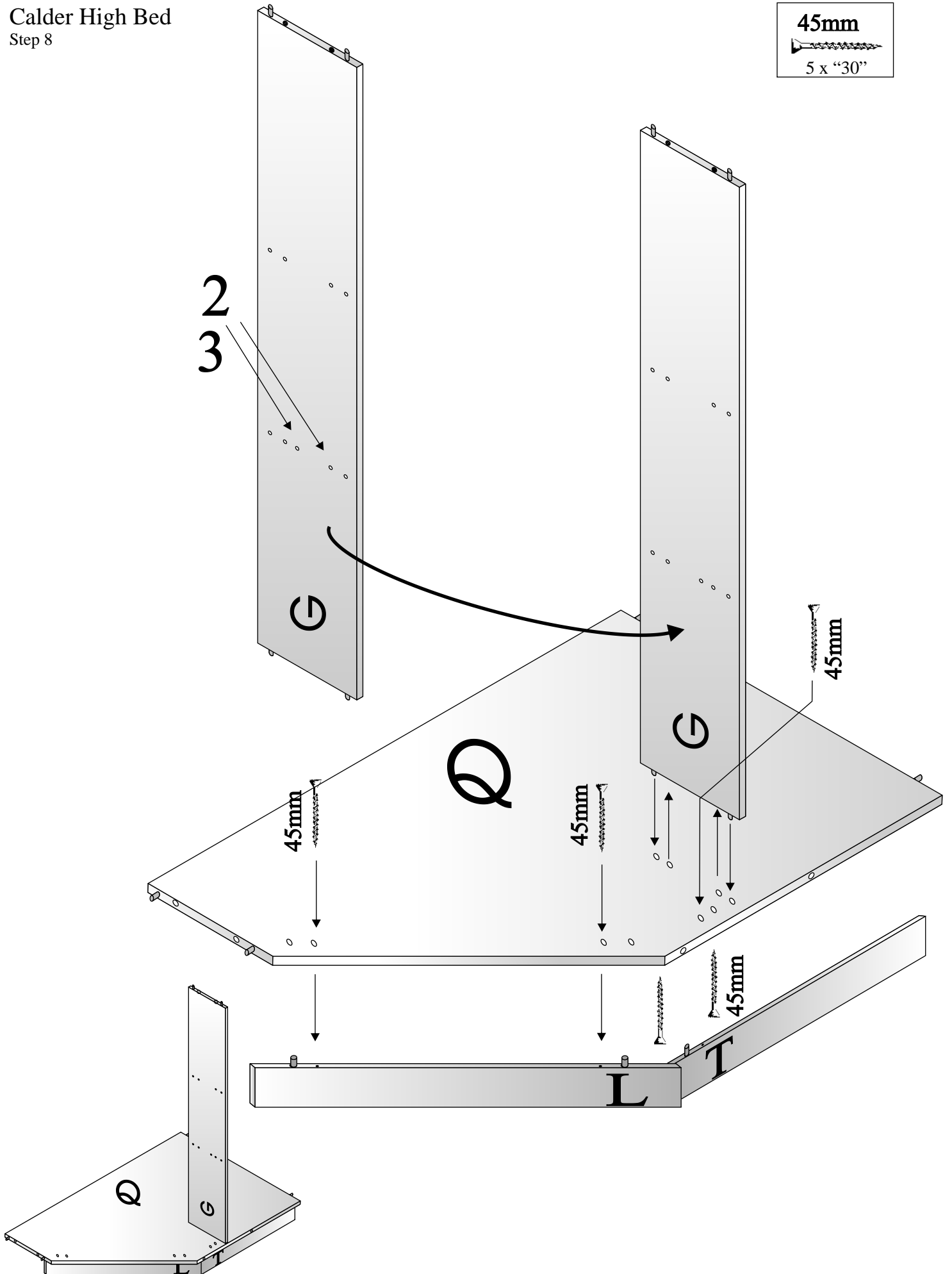

Calder High Bed

Step 9

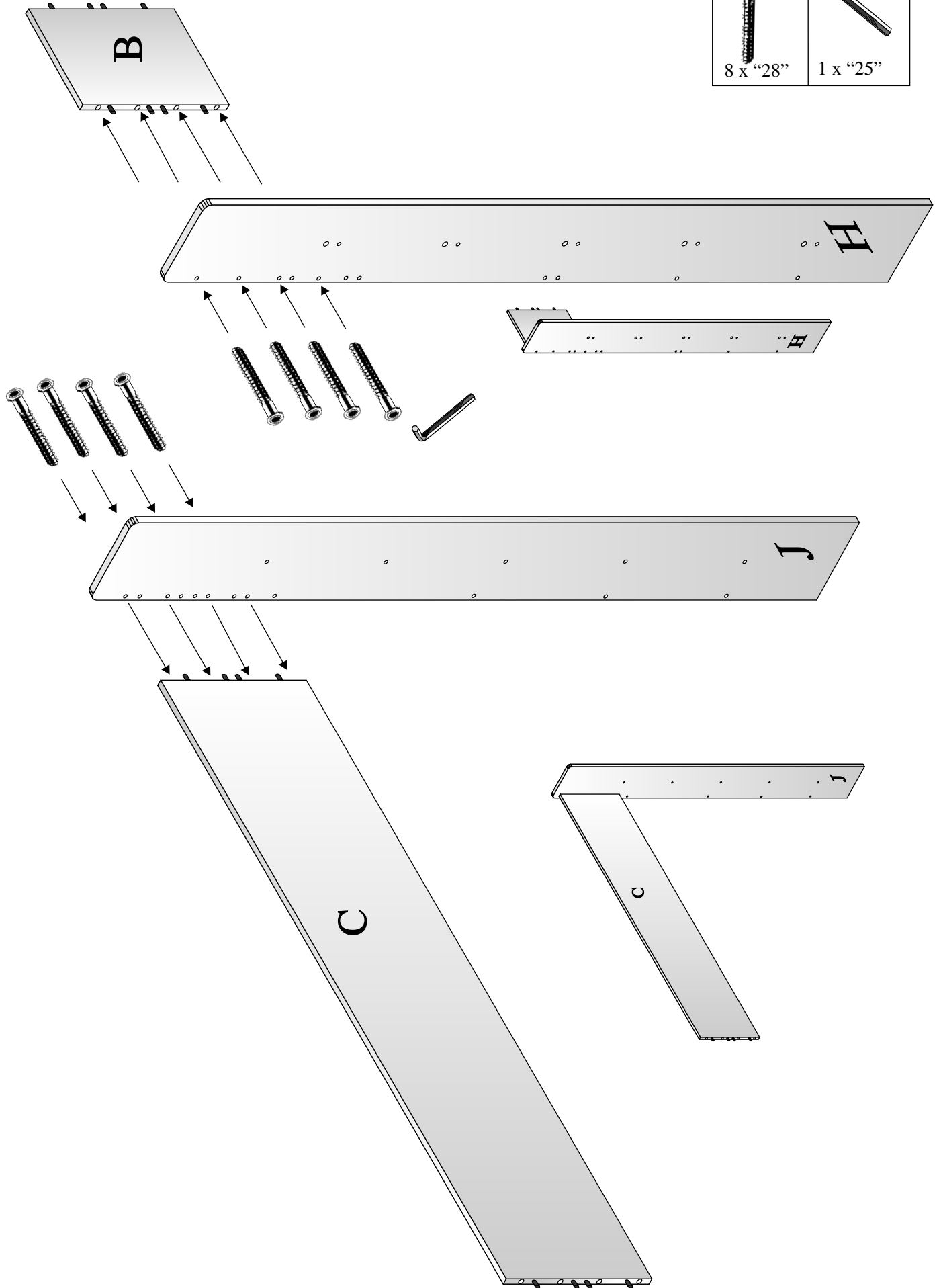
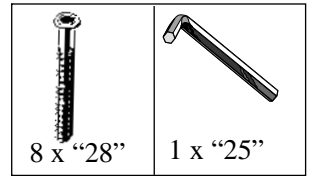

Calder High Bed

Step 10

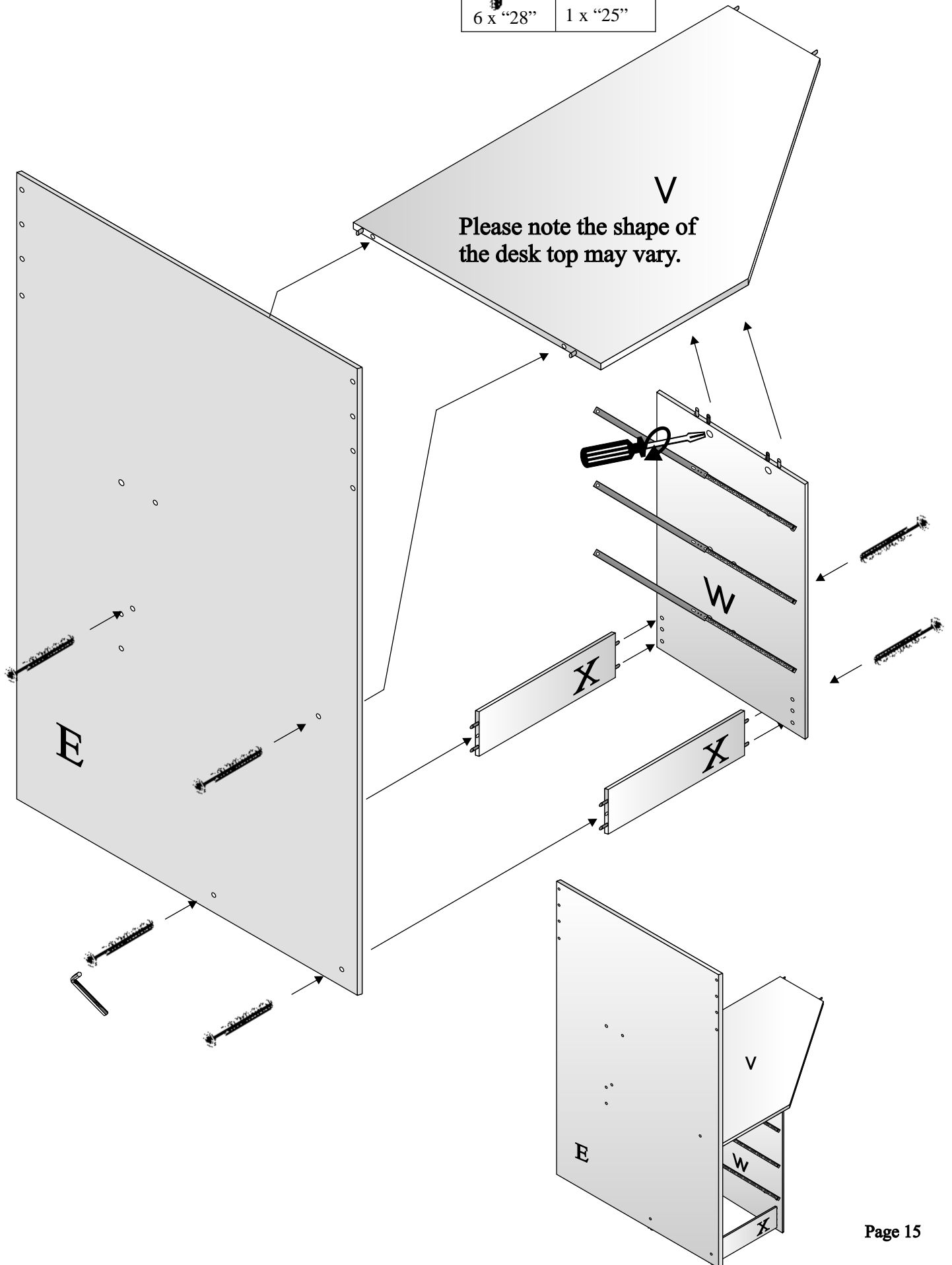
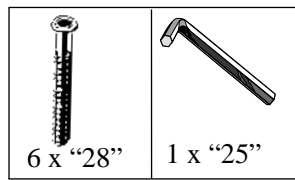

Calder High Bed
Step 11

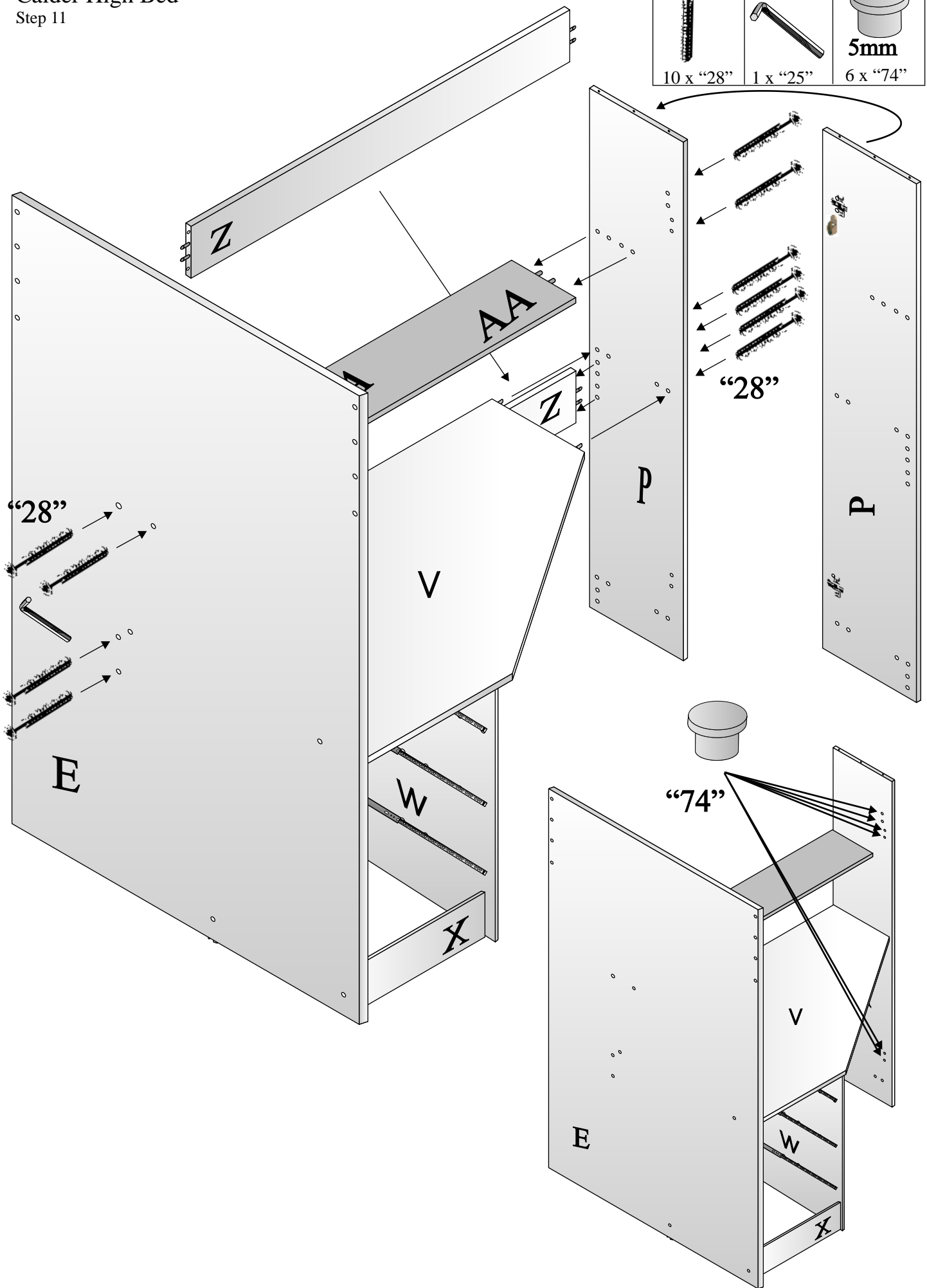
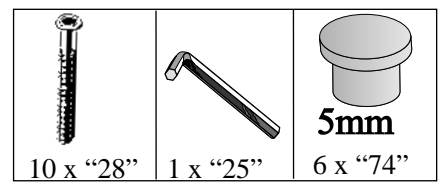

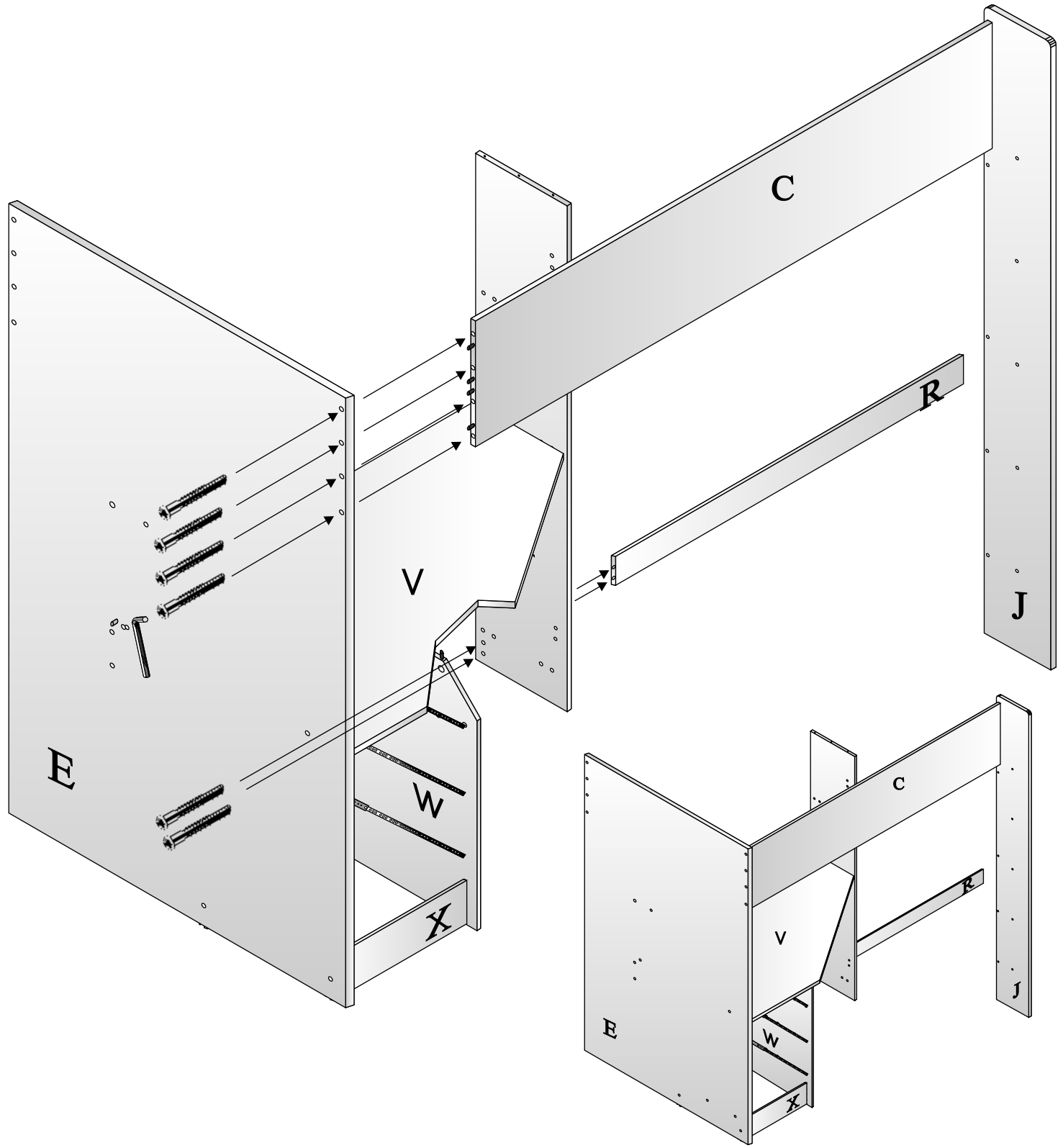
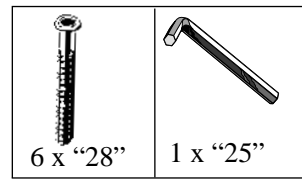

Calder High Bed

Step 12

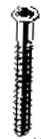

Calder High Bed
Step 13

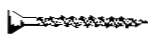
 2 x "28"	 1 x "25"	 45mm 5 x "30"
--	--	--

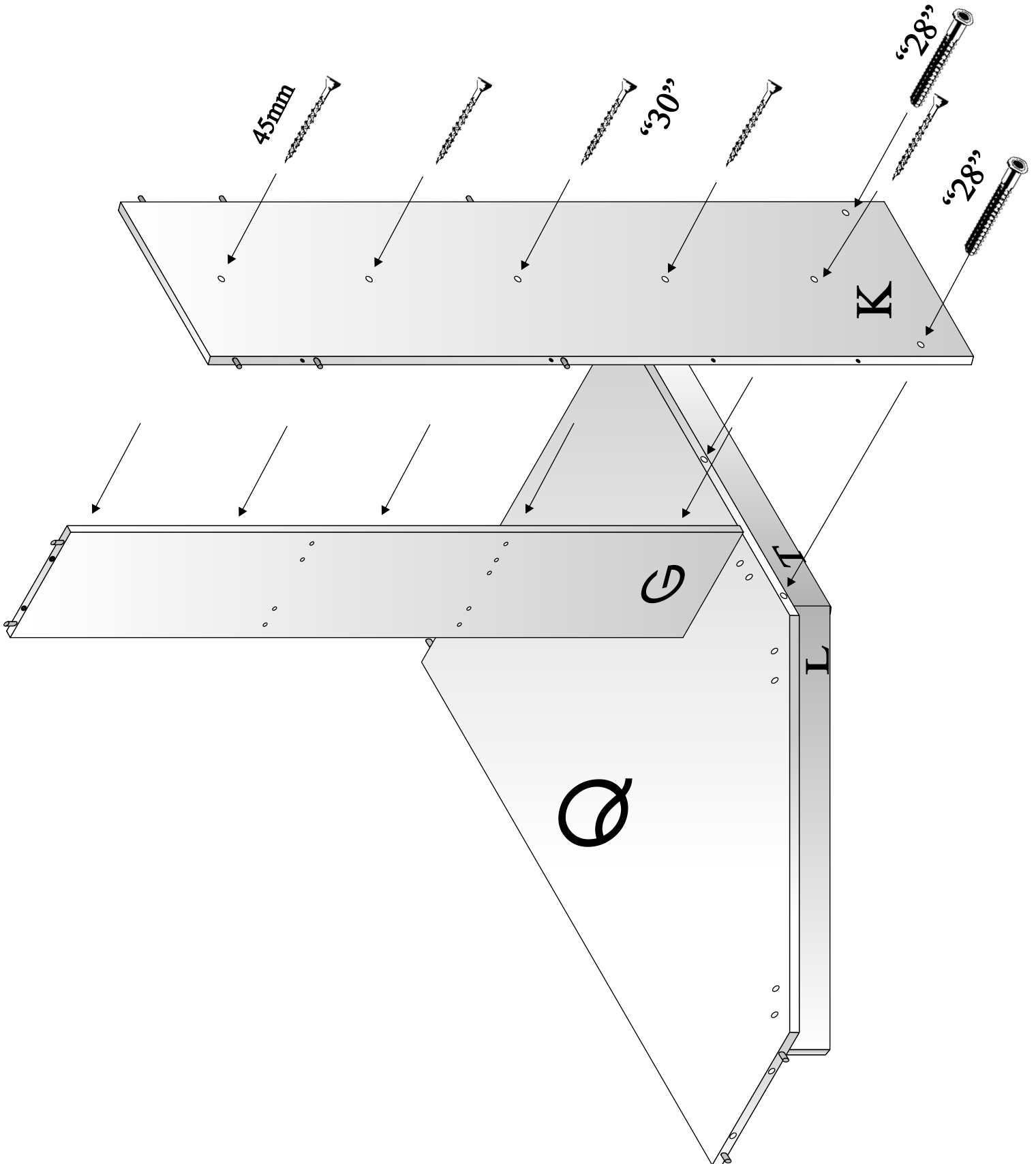

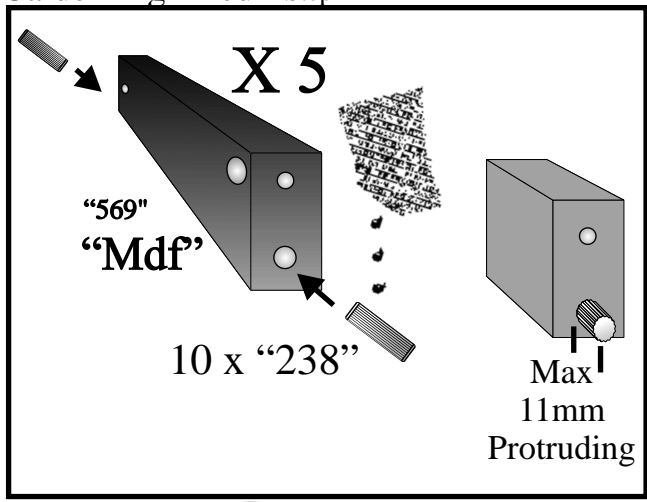



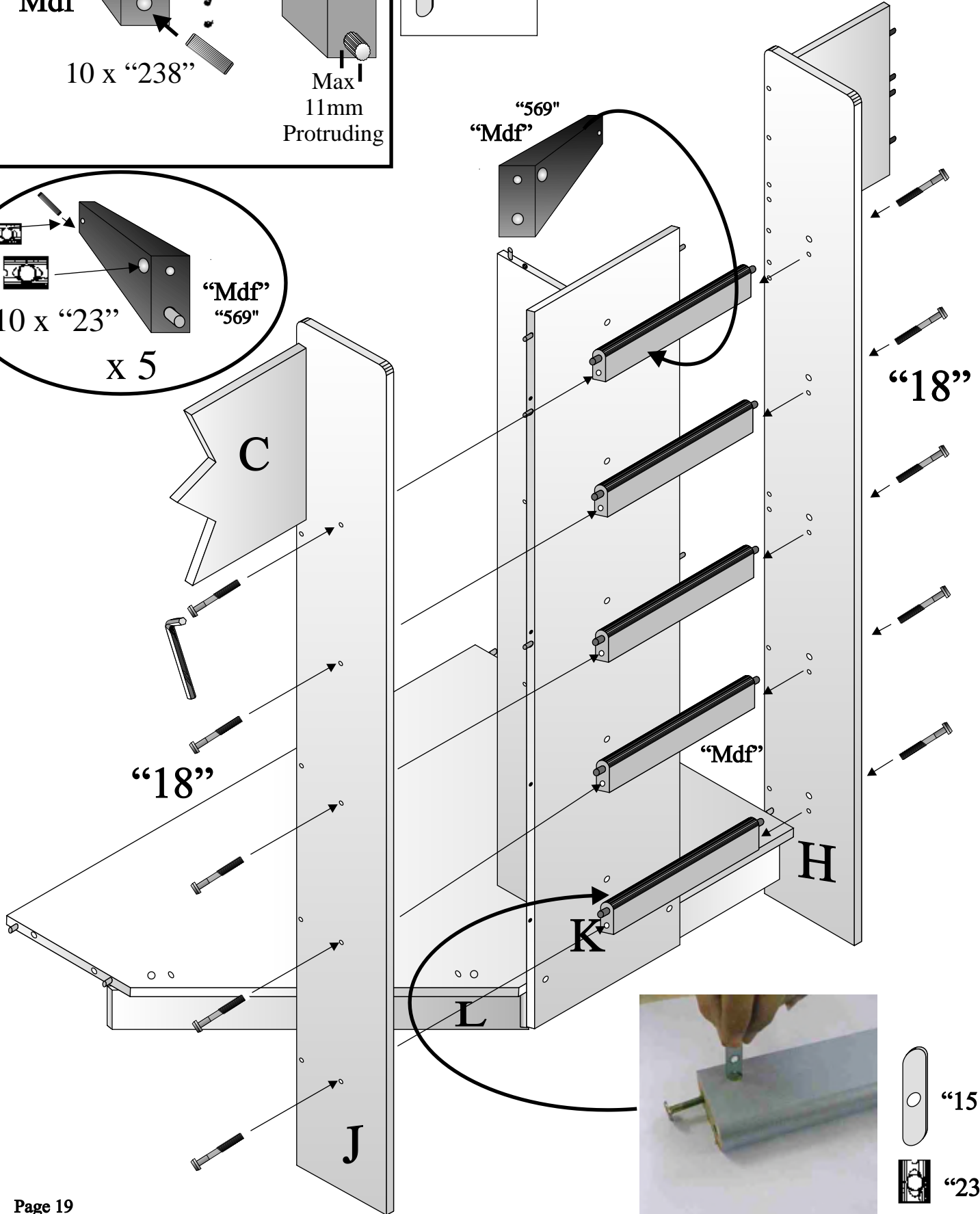
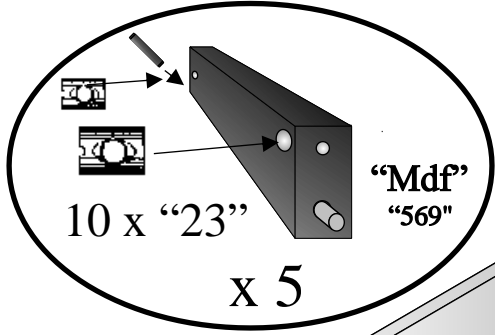

50mm x 10mm x "238" 10 x "238"	"219"	50mm x M6 10 x "18"	10 x "23"	1 x "25"
1 x "151"				



Calder High Bed
Step 15

			
2 x "28"	1 x "25"	45mm 8 x "30"	6mm 2 x "92"

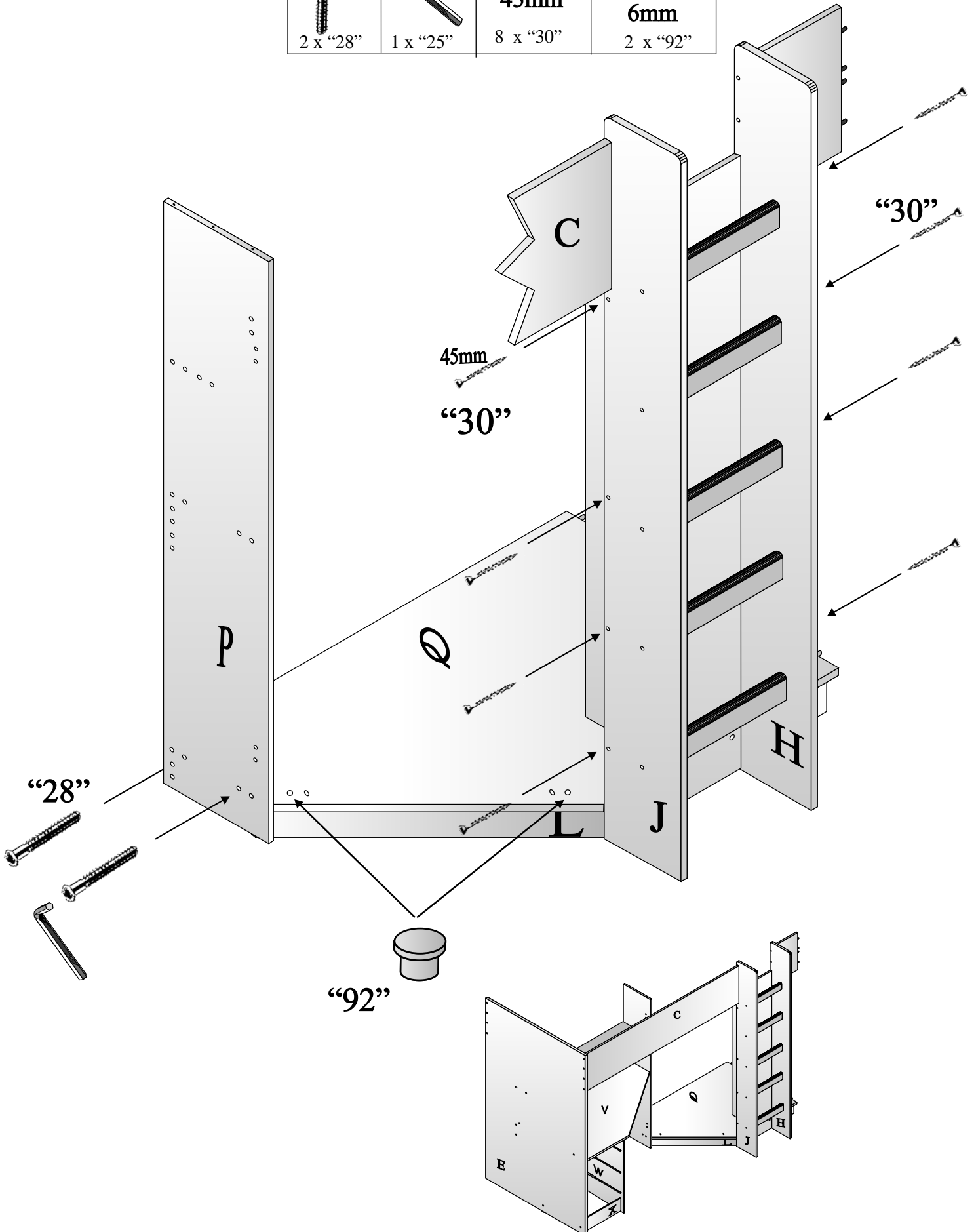

Calder High Bed
Step 16

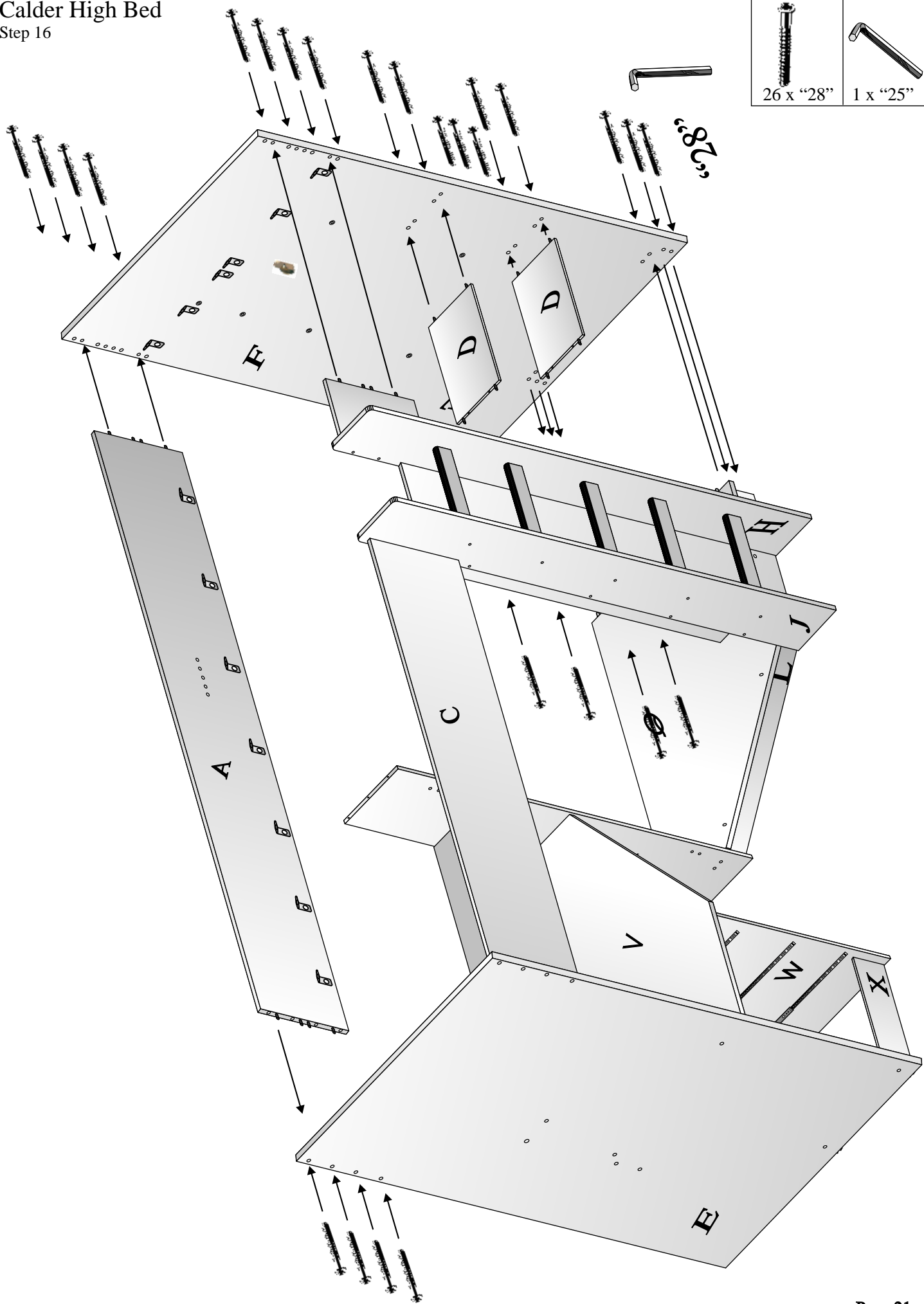
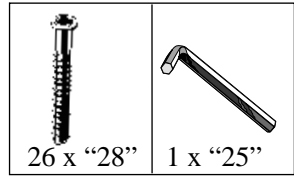



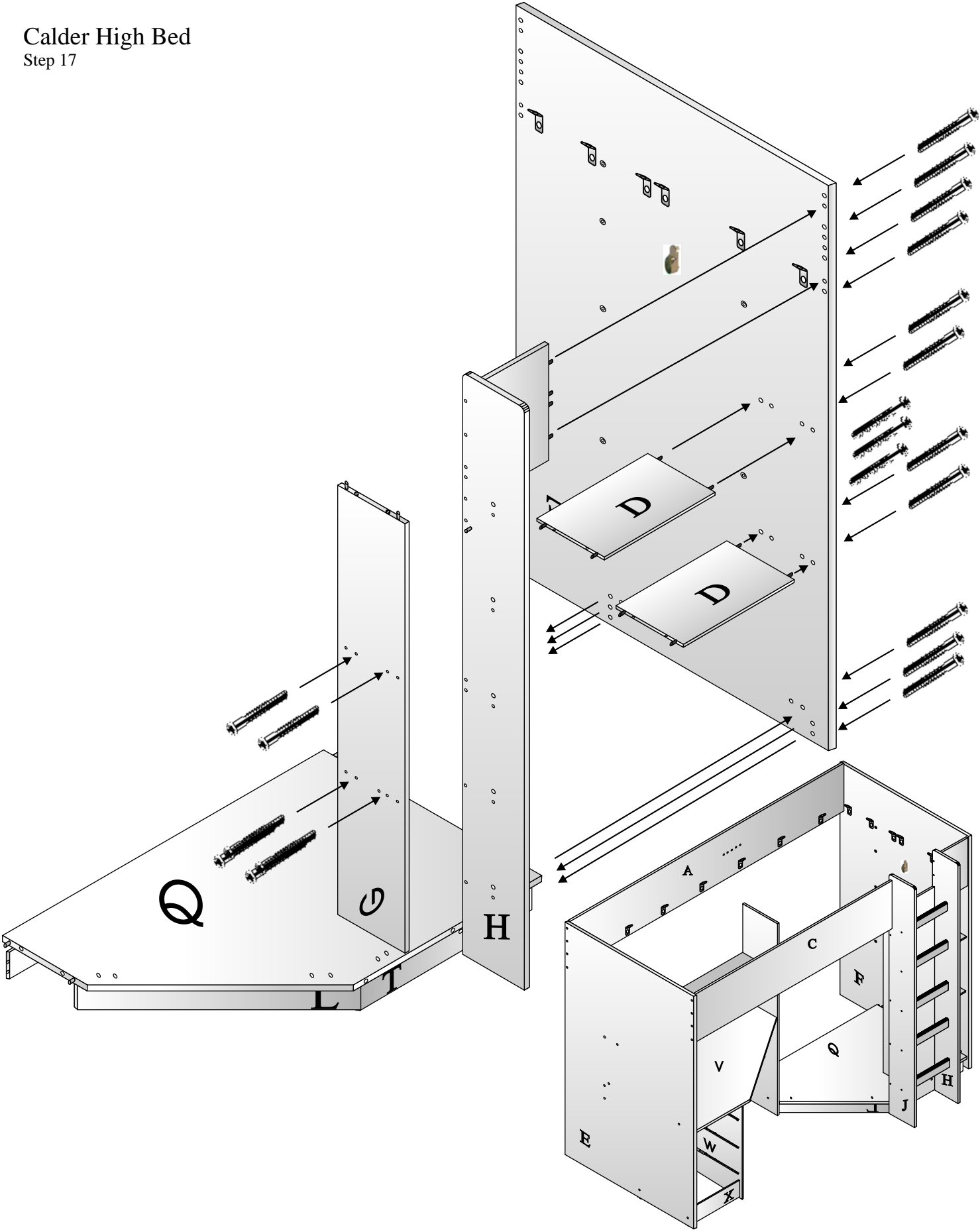

Calder High Bed

Step 17



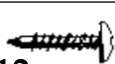

Calder High Bed

Step 18

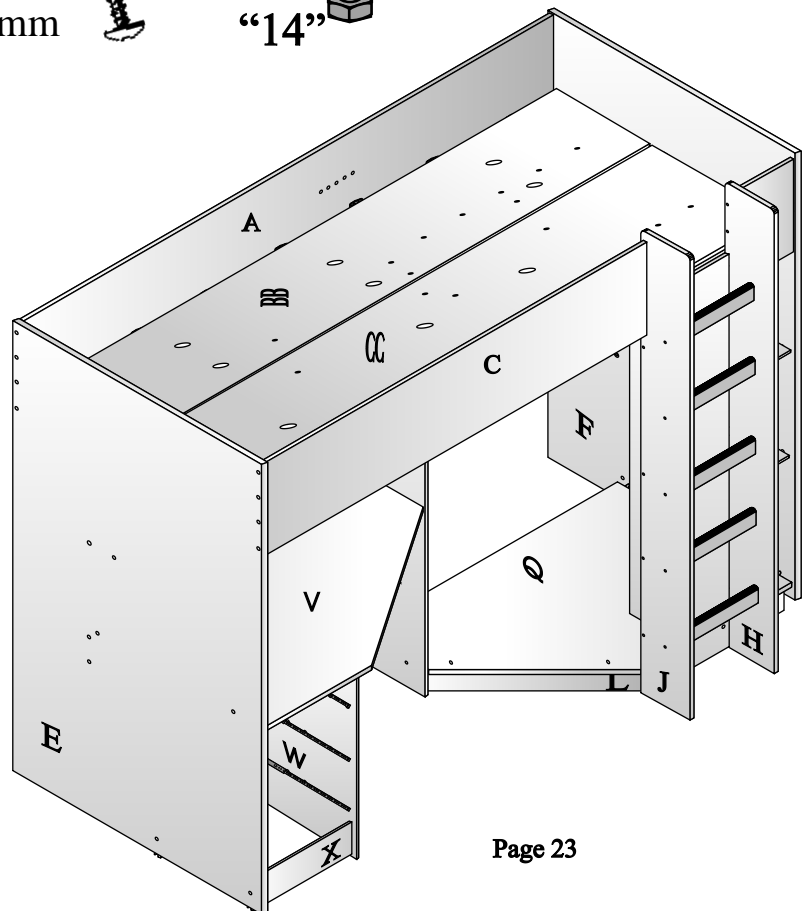
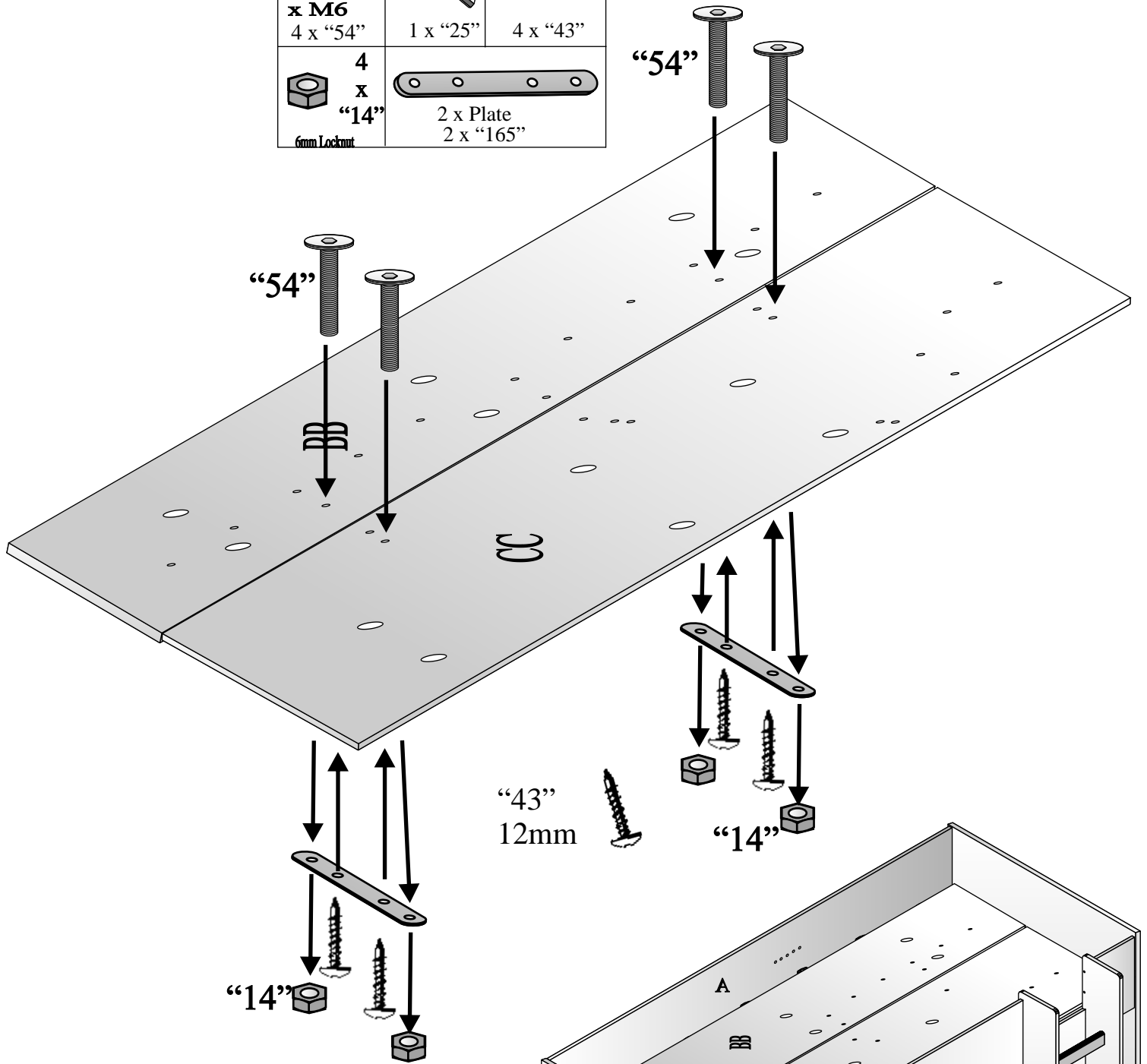
 26mm x M6 4 x "54"  4 x "14" 6mm Locknut	 1 x "25"	 12mm 4 x "43"
 2 x Plate 2 x "165"		

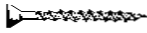

Calder High Bed
Step 19

	
45mm	12mm
5 x "30"	28 x "43"

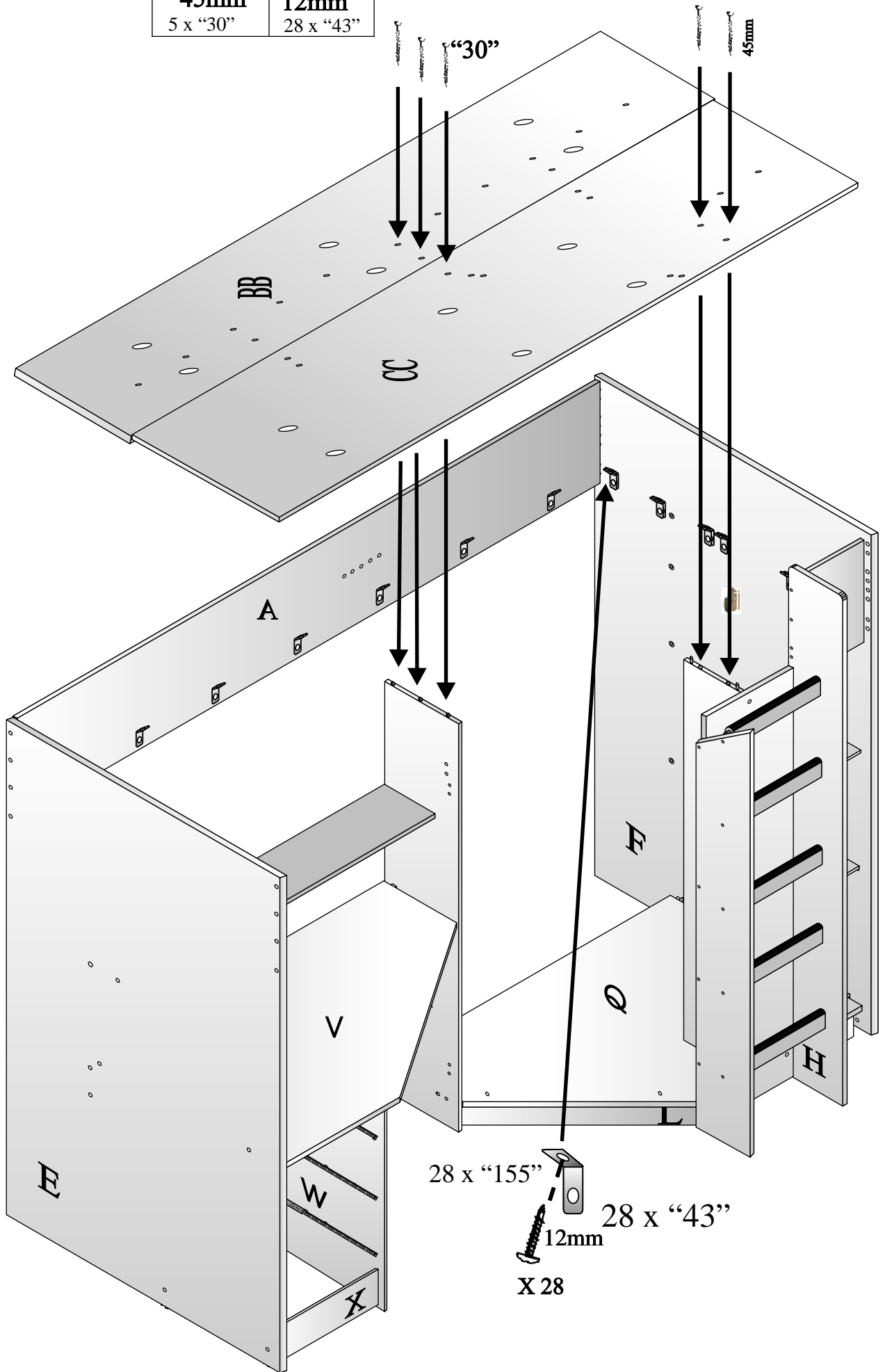

Calder High Bed
Step 20

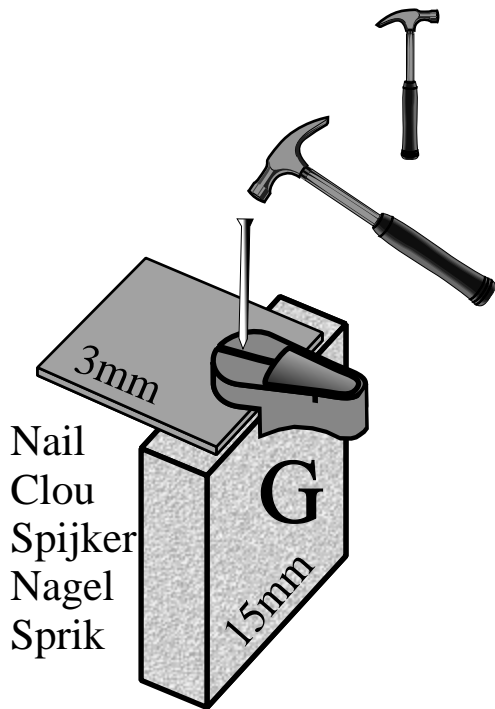
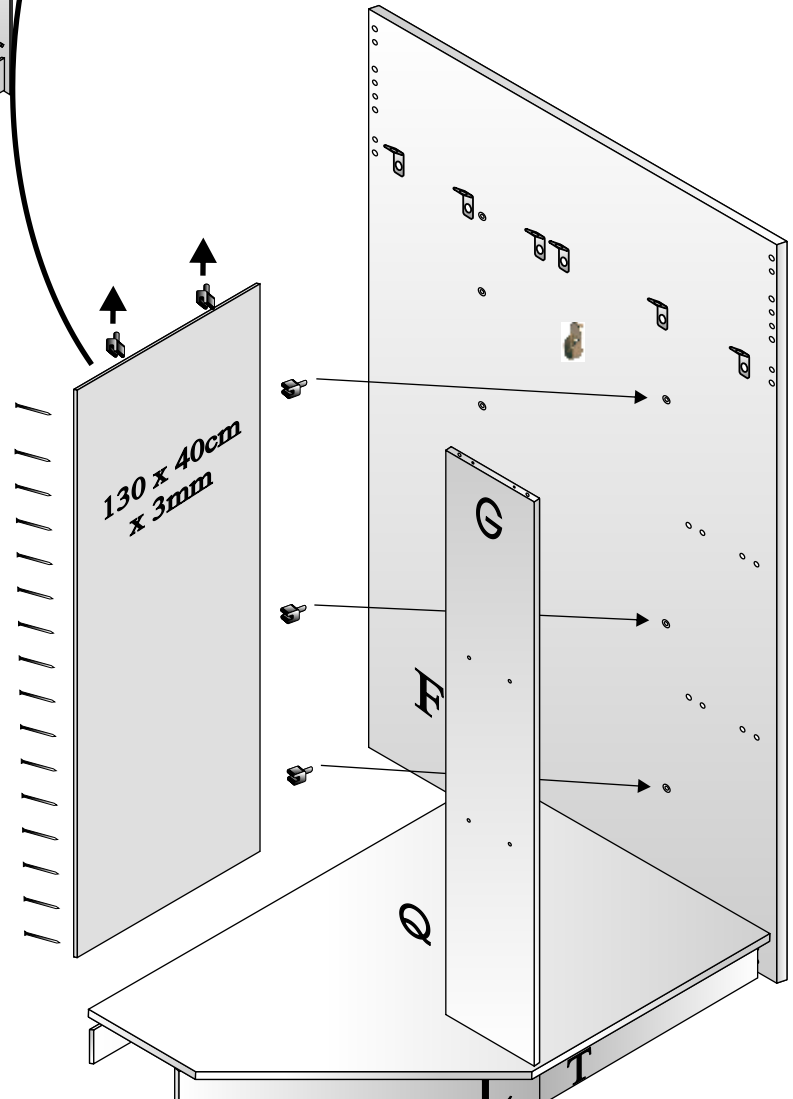
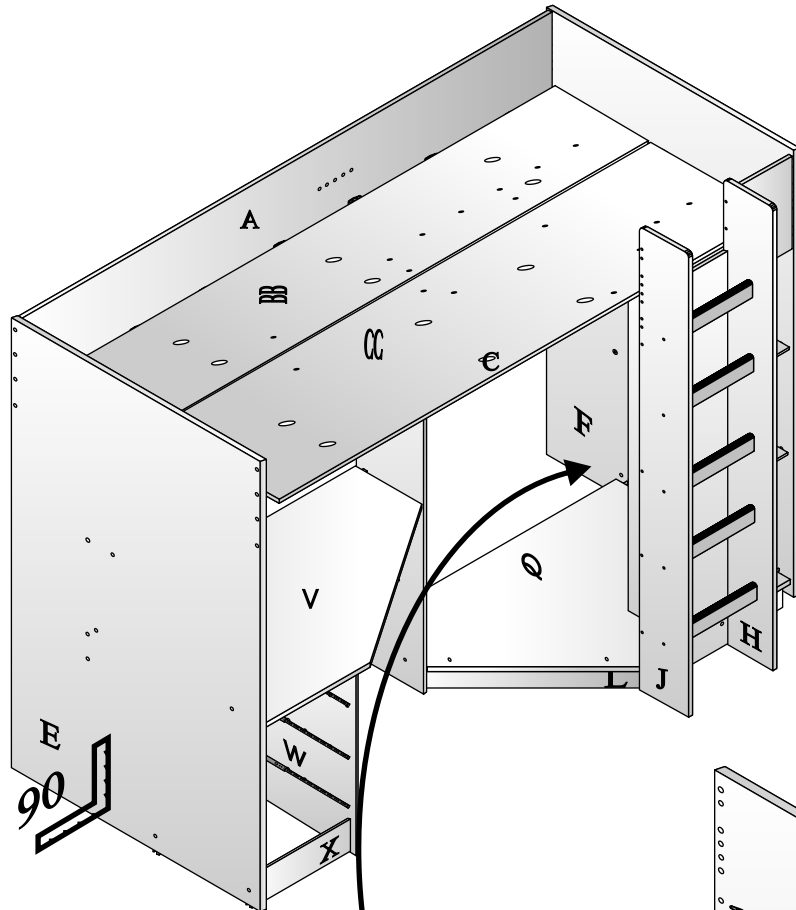
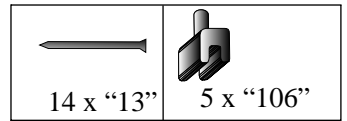



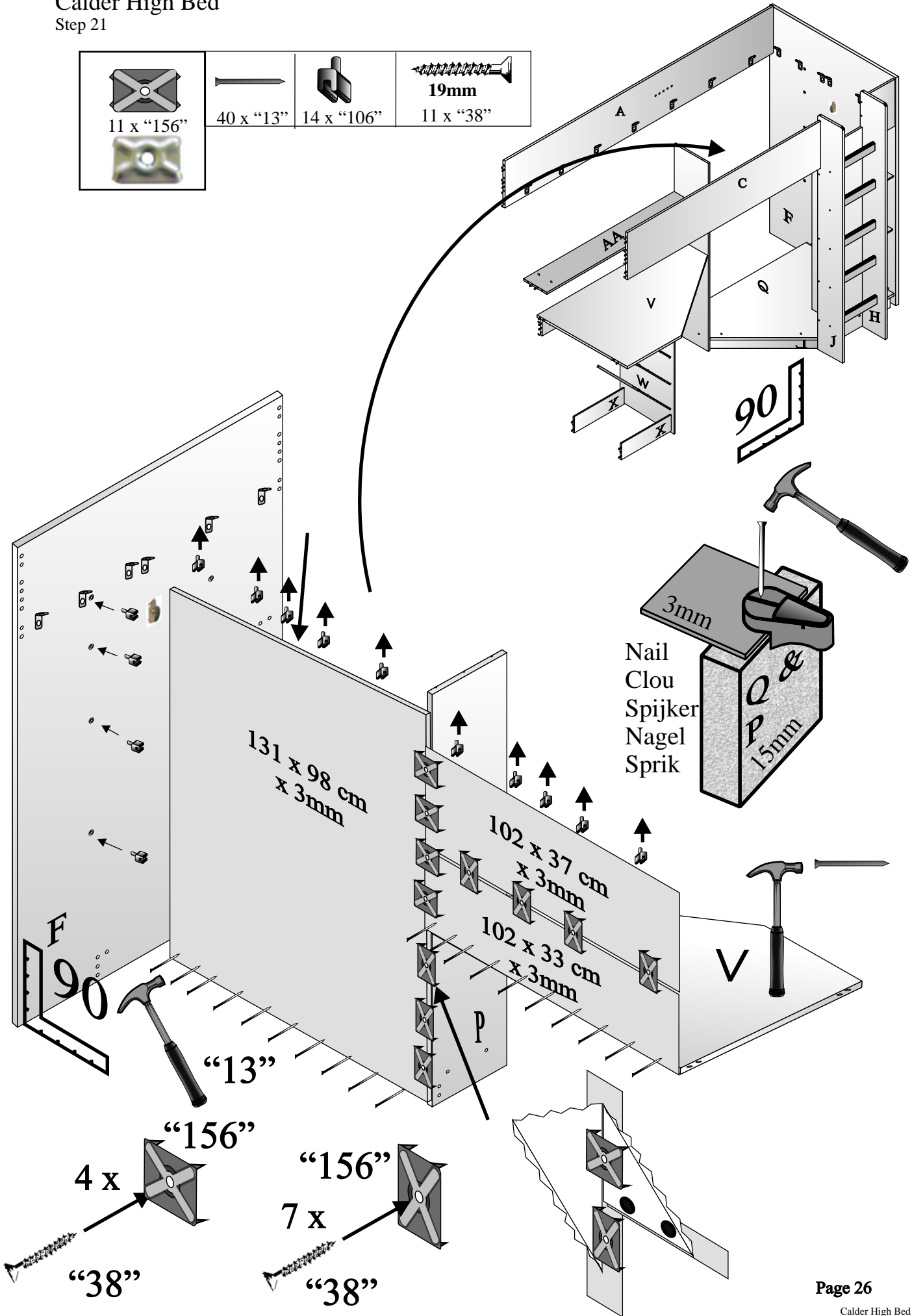
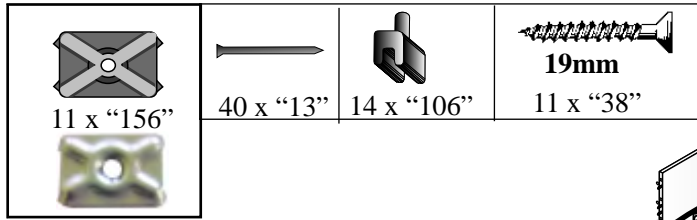

Calder High Bed

Step 21





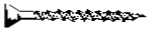

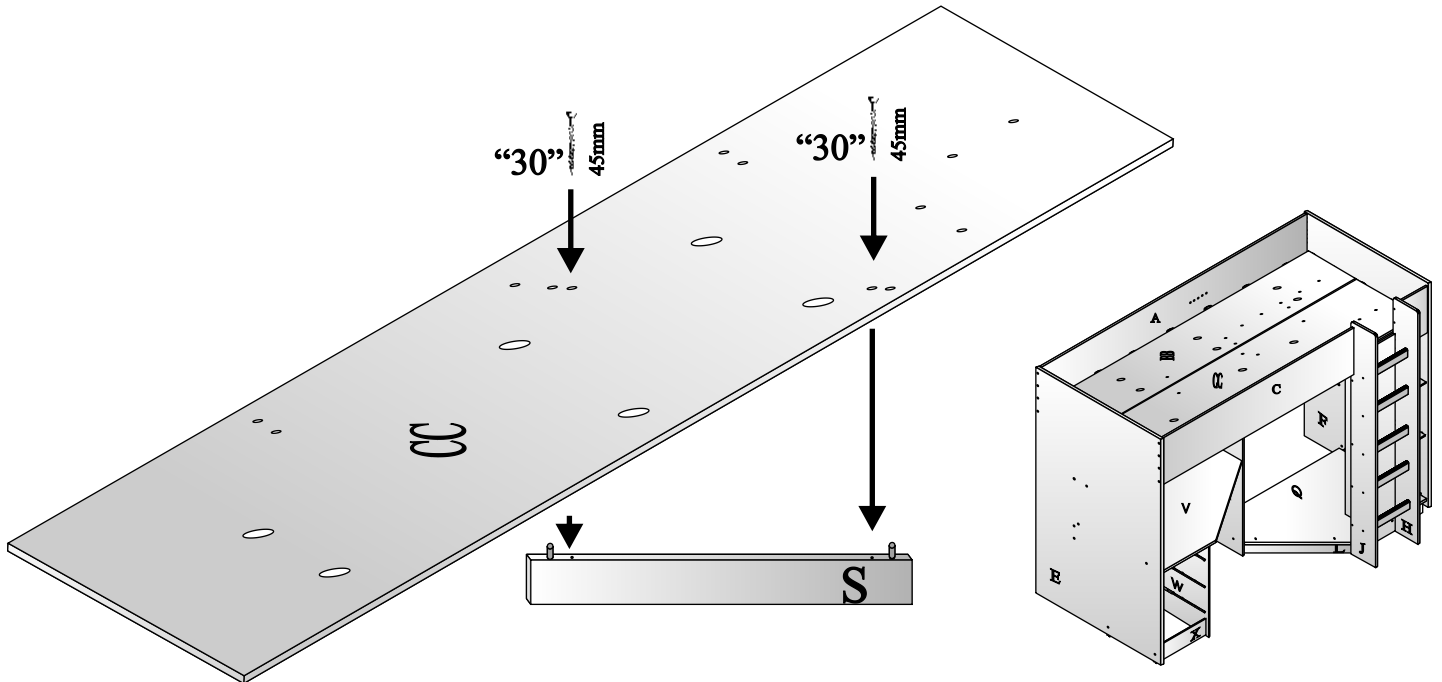
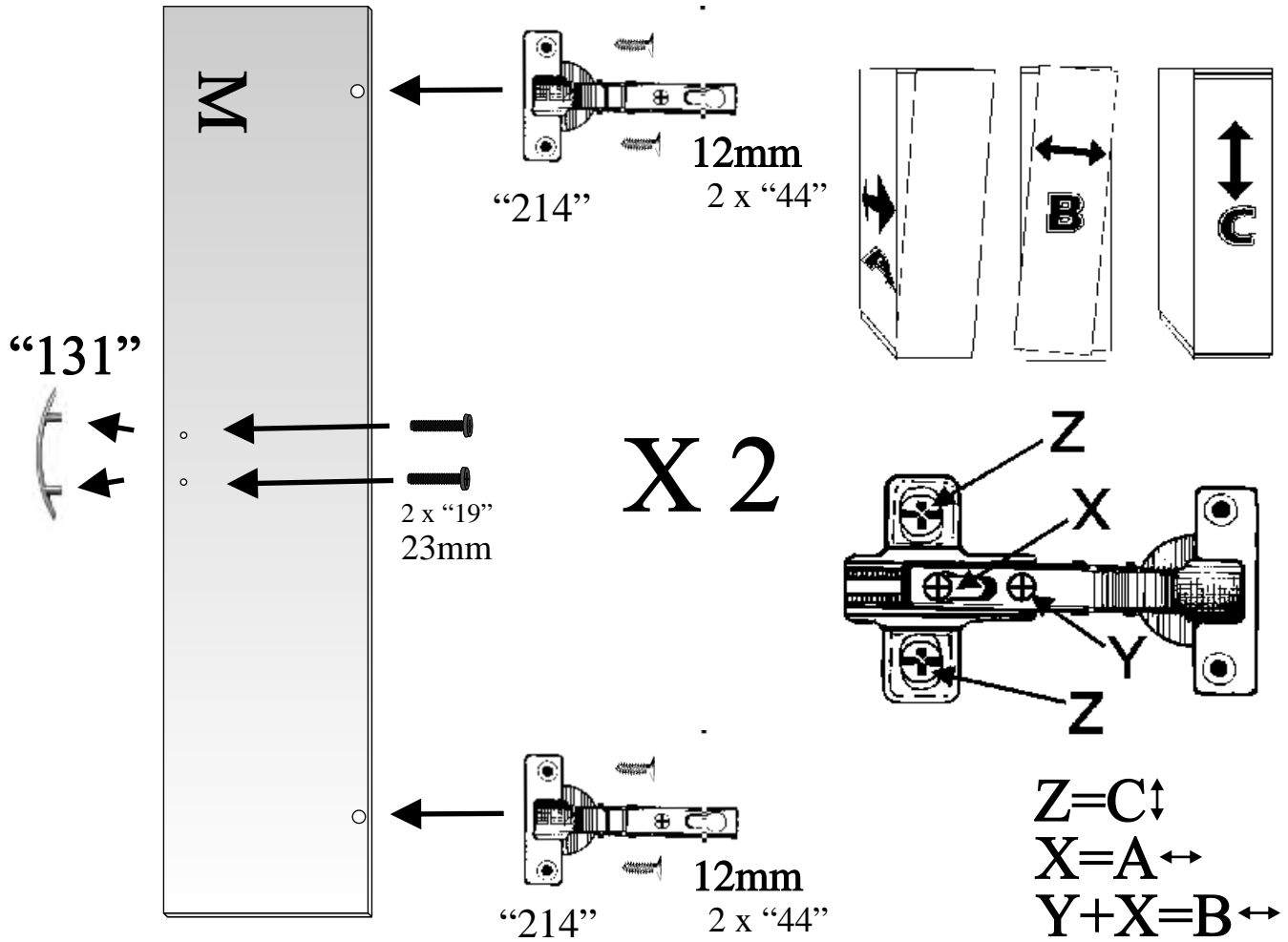
Calder High Bed
Step 22

				
23mm	12mm	45 degrees	2 x "131"	45mm
4 x "19"	8 x "44"	4 x "214"		2 x "30"



Calder High Bed
Step 23

'131'		3
'19'	 23mm	6
'219'		3
'124'	 96cm	1

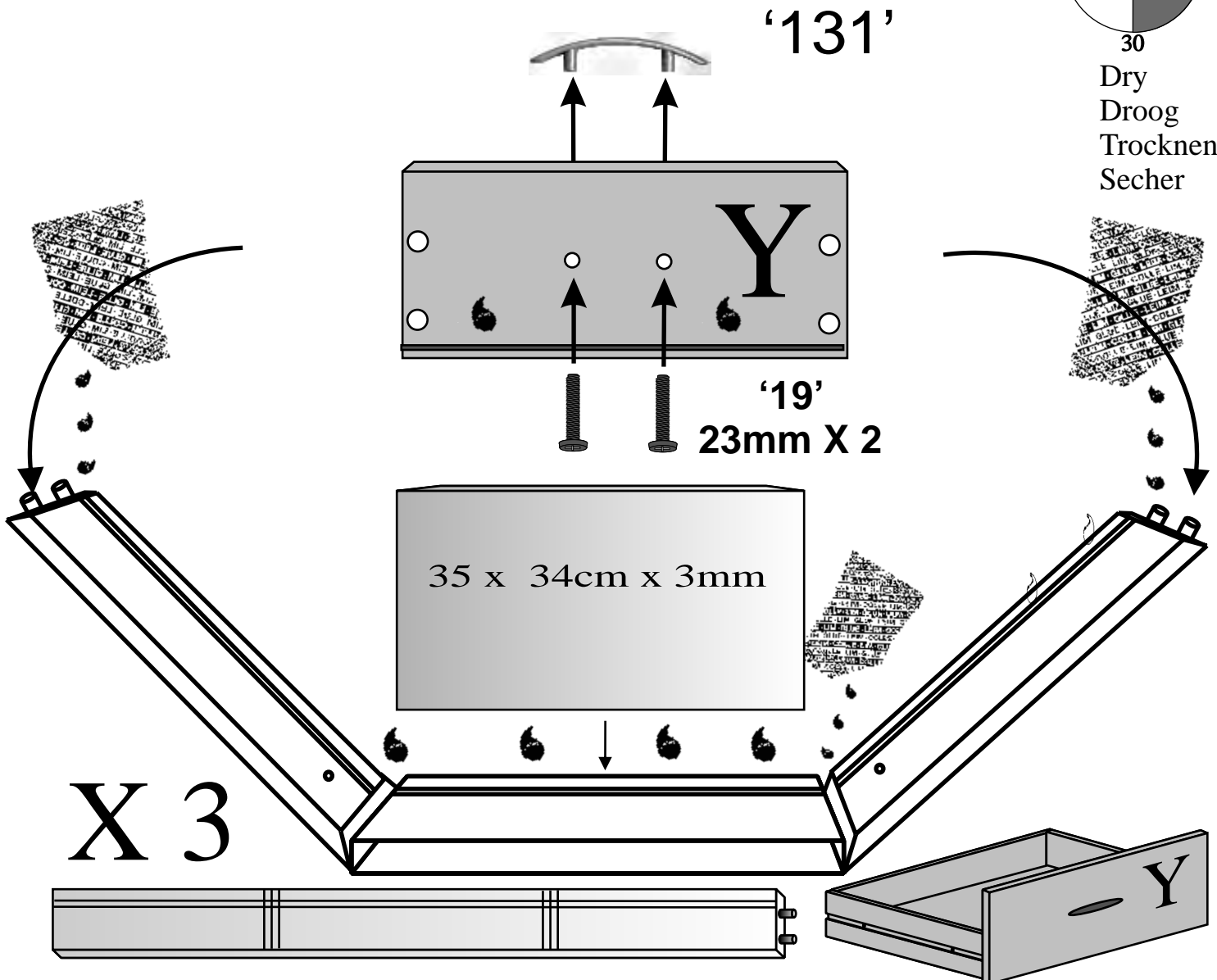
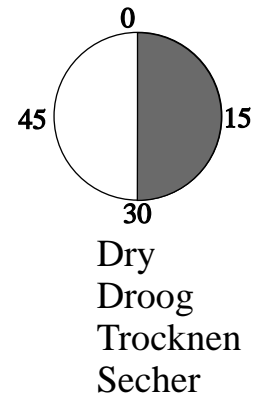
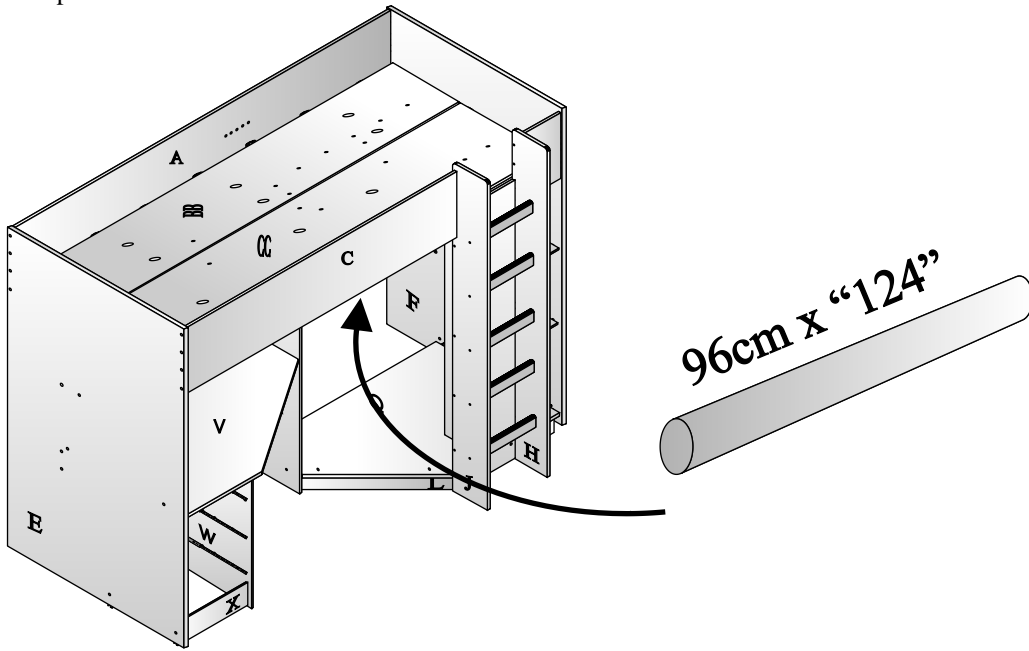

'47'	 10mm	6
------	---	---

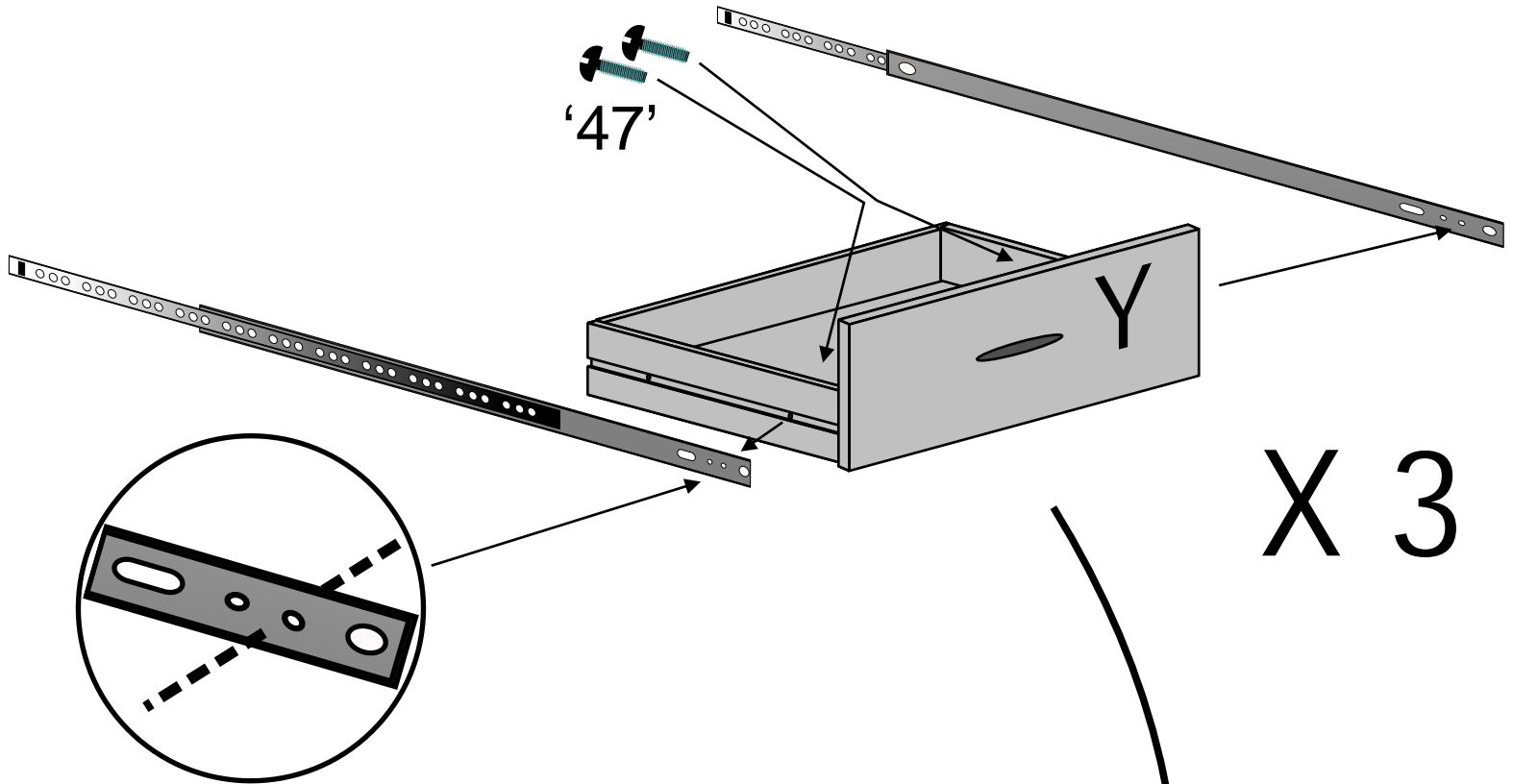

X 3

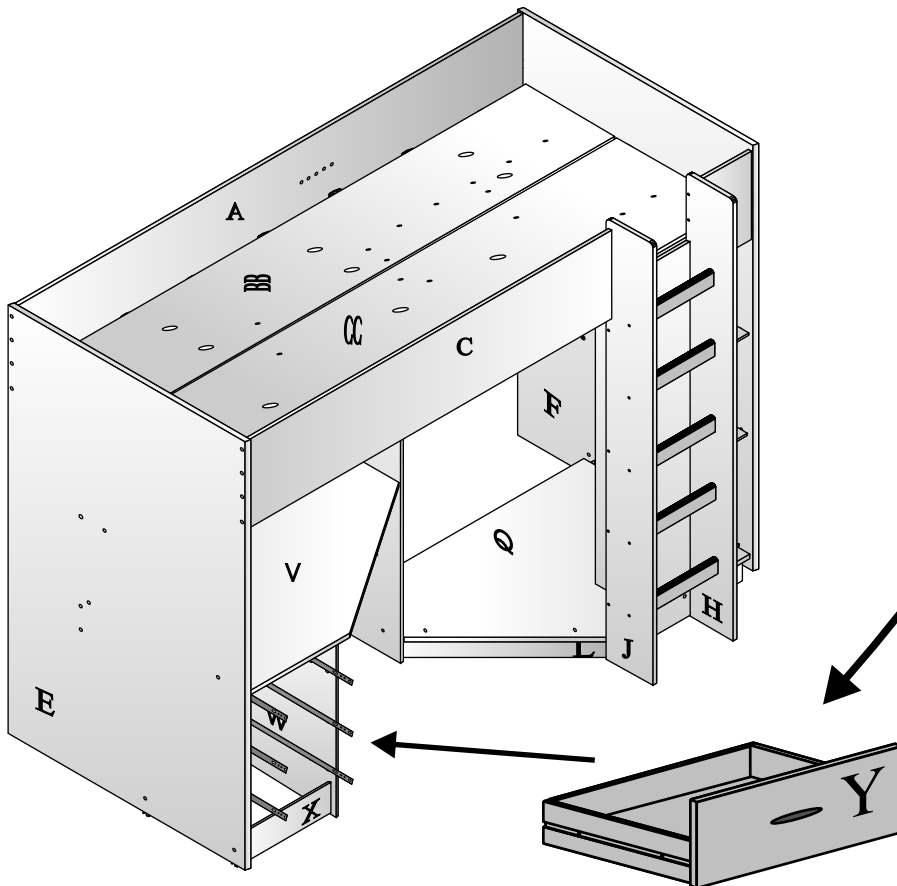

After assembly discard any extra fittings.
In het componenten pak zitten extra
schroeven etc., na de opbouw kunnen
deze weggegooid worden.
Après Assemblage, se débarrasser de pièces
de plus.

UK Spares and Assembly HELPLINE 01572 755110
Manufacturer - Belvoir Associates Ltd
Pillings Road Oakham England